



QUALITY... PLAIN & SIMPLE®

## Ford C6 Cable Operated Shifter Installation Instructions

# Ford C6 Cable Operated Shifter Installation Instructions

Building American Quality... With A Lifetime Warranty!®

TOLL FREE 1-877-469-7440 • tech@lokar.com • www.lokar.com

### General Installation Notes:

Please read these instructions completely before beginning the installation. If you have any questions please call.

Before beginning the installation, disconnect the negative battery cable and use wheel chocks to block the vehicle's wheels.

Make sure the engine, transmission, body and frame are properly grounded.

Refer to Figs. 1, 2 and 3 for the component names.

### Tools and Materials Required:

- Standard Allen wrenches: 1/8", 5/32", 3/16"
- Wrench or Socket Sizes: 3/8", 7/16", 1/2", 9/16", 7/8", 15/16"
- Tape Measure
- Metal cutting tool, such as a hacksaw or a die grinder with a cut-off wheel
- Drill and 5/16" drill bit
- Ohmmeter
- Wire cutters/strippers
- Wire crimping or soldering tools
- Blue thread locking compound

Lokar Shifters are designed to fit specific transmissions. Before installing the shifter, verify that you have the proper model for your transmission. If your shifter does not seem to connect to the transmission properly, do not make modifications during installation as this may void your warranty. Call for assistance.

Verify that the shifter length you have purchased is what you actually want. When installed, the bottom of the shifter lever will be approximately 3-1/2" - 4" above the bottom of the floor mount mounting bracket. From that point up to the top of the knob is how the shifter length is determined.

The shifter must be installed into the vehicle before attempting to make any adjustments.

The shifter is designed to lock in Park and in Neutral. You must depress the release button in the top of the shifter knob in order to shift out of Park or Neutral.

To shift from Park directly to Drive, depress the release button and hold it down while moving the shifter lever, and the shifter will automatically stop in Drive. Once you release the button, the shifter will allow you to move the lever into the next lower gear. You must depress the button to shift down again.

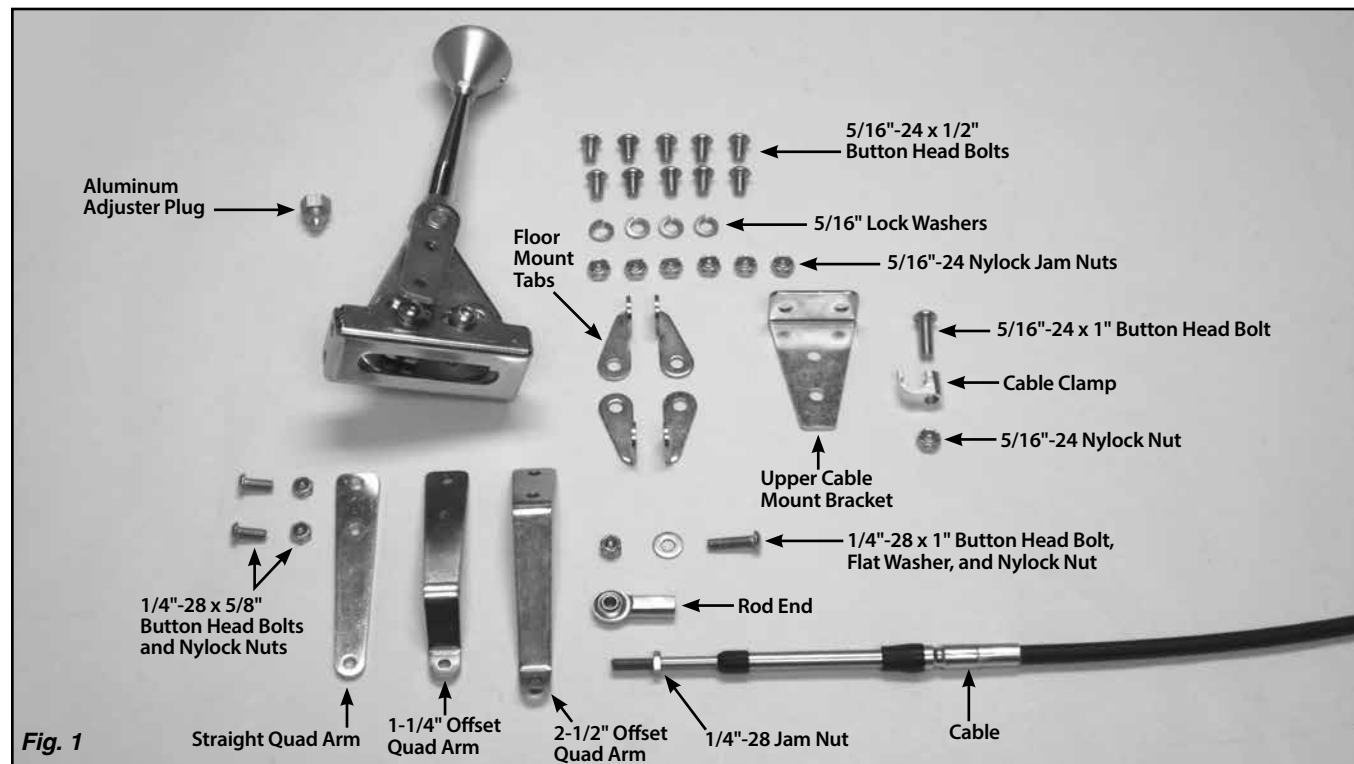


Fig. 1

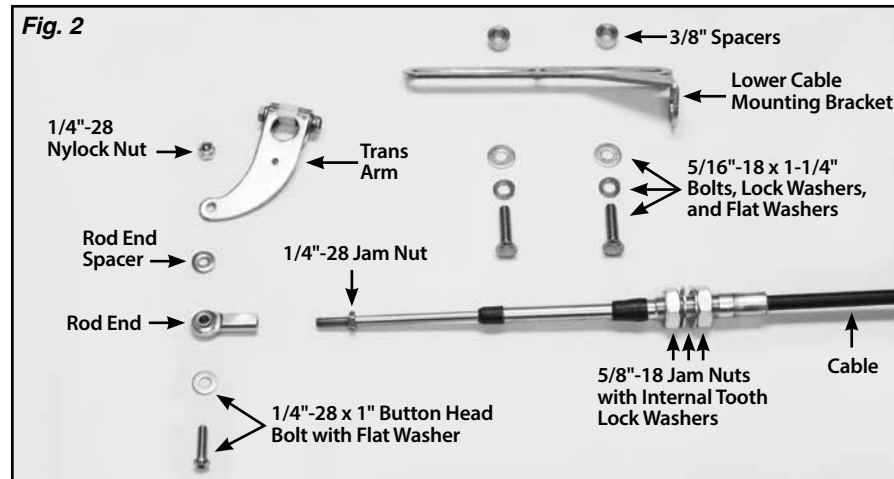


Fig. 2

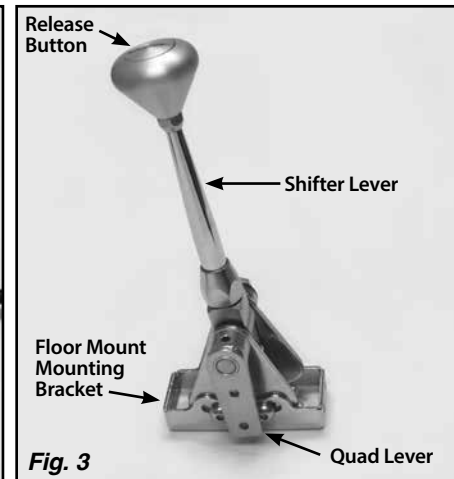
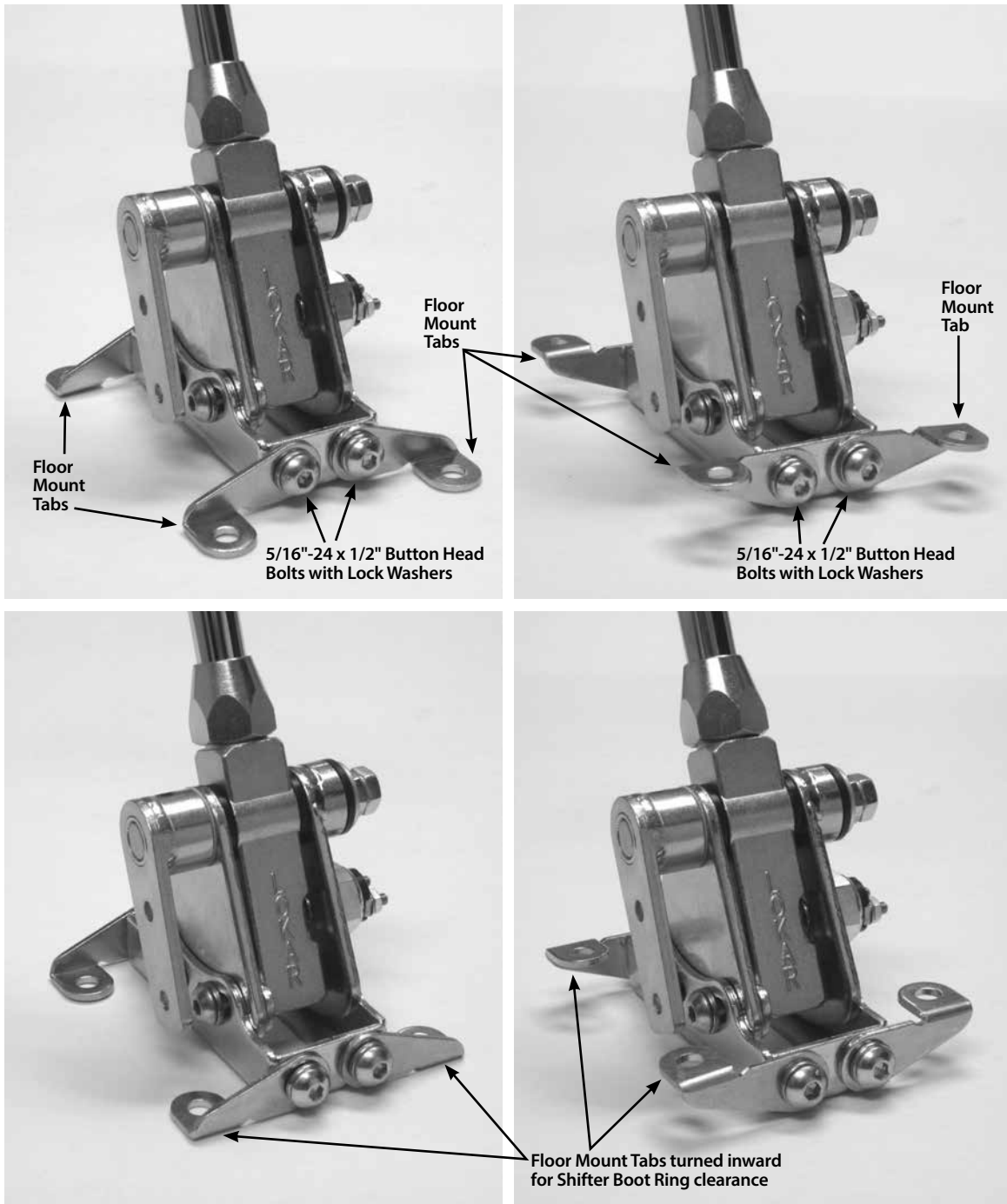


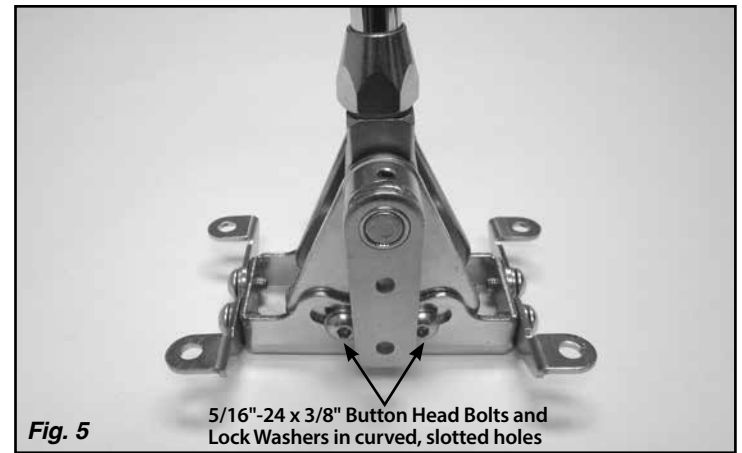
Fig. 3

**Above Floor Installation**

**Below Floor Installation**



**Fig. 4**



**Fig. 5**

**5/16"-24 x 3/8" Button Head Bolts and Lock Washers in curved, slotted holes**

**Step 1:** If your vehicle already has a shifter of any type installed, disconnect all shifter linkage and remove the shifter and its related hardware (neutral safety switch, back-up light switch, etc.).

**Step 2:** Determine exactly where you want the shifter to be located. The shifter may be mounted either on top of the floor or underneath the floor.

**NOTE:** For vehicles that had a floor shifter previously, determine if the existing hole in the floor will be adequate for mounting and operation of the Lokar shifter. If not, the floor will need to be modified.

If you are mounting the shifter on top of the floor, you will need a slot in the floor for the quad arm to pass through. If you are mounting the shifter underneath the floor, you will also need an opening for the floor mount mounting bracket.

**Step 3:** There are two pairs of floor mount tabs in the shifter kit. How they are arranged when installed on the shifter depends on whether you are mounting the shifter above or below the floor, and on the size of the shifter boot ring if you are installing a shifter boot and ring directly on the floor. If you are using the Lokar rectangular shifter boot and ring, at least two of the floor mount tabs (both front or both rear) must be installed pointing inward.

See **Fig. 4** to determine how the floor mount tabs need to be positioned for your particular application.

Attach the floor mount tabs to the floor mount mounting bracket as shown in **Fig. 4** with the 5/16"-24 x 1/2" button head bolts and lock washers. Leave the bolts loose enough so that adjustments can be made later during the installation.

**Step 4:** Make sure the two 5/16"-24 x 3/8" socket head bolts that are in the curved, slotted holes in the left side of the floor mount mounting bracket are tight. Place the shifter in the desired location. Make sure the shifter will not interfere with the dash when in Park, or with the seat when in low gear. The shifter assembly may be tilted forward or backward if needed by loosening the two socket head bolts that are in the curved, slotted holes in the left side of the floor mount mounting bracket. Retighten the socket head bolts in the curved, slotted holes once you have the shifter assembly at the angle you want. **Fig. 5**

**Note:** If you ever disassemble the shifter assembly, be sure that the 5/16"-24 x 3/8" button head bolts and lock washers are put back into the curved, slotted holes in the floor mount mounting bracket. Installing longer bolts will prevent the shifter from operating.

Push the floor mount tabs flush against the floor, and mark the center of the bolt holes in the floor mount tabs onto the floor. Center punch the marks, and drill four 5/16" diameter holes.

**Step 5:** Attach the shifter to the floor using four 5/16"-24 x 1/2" button head bolts and nylock jam nuts. Once the shifter is mounted to the floor, tighten the bolts that attach the floor mount tabs to the floor mount mounting bracket.

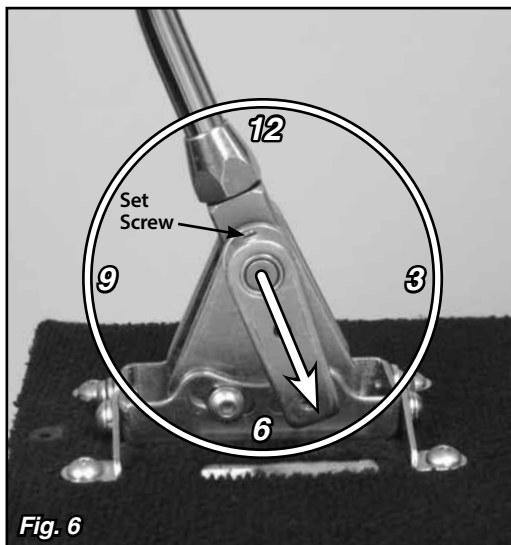


Fig. 6

**Step 6:** Make sure the shifter is in Park. Check the position of the quad lever. It should be pointing to about the 5:00 position. If it is not, loosen the set screw in the top of the quad lever with a 1/8" Allen wrench and slide the quad lever off of the shaft. Reposition it on the shaft at approximately the 5:00 position, and retighten the set screw. **Fig. 6**

Determine which one of the quad arms included in the kit should be used to mount to the quad lever. There are three different options to choose from: straight, 1-1/4" offset and 2-1/2" offset.

**NOTE:** For the best results, use the quad arm with the least amount of offset that will still clear the transmission and work for your application.

Install the quad arm onto the quad lever using the two 1/4"-28 x 5/8" button head bolts and nylock jam nuts. **Fig. 7**

**Step 7:** Make sure the transmission is in Park by rotating the original trans arm clockwise as far as it will go. Remove the rod end from the new trans arm. Remove the tape from the pinch bolt, and position the trans arm with the pinch bolt, flat washers, and nylock nut onto the transmission gear selector shaft.

If your original trans arm interferes with the new trans arm, the original trans arm must be cut off of the selector shaft. It is much easier to cut the trans arm off of the selector shaft if you remove the selector shaft from the transmission first. If you remove the selector shaft, we recommend that you install a new selector shaft seal (not included) when reassembling.

The new trans arm should be pointed down and towards the front. The 1/4" hole in the end of the trans arm needs to be aligned directly below the band adjustment nut on the side of the transmission. Tighten the nylock nut on the pinch bolt to hold the trans arm in position on the selector shaft. **Fig. 8**

**Step 8:** Install the lower cable mounting bracket on the left side of the transmission pan, using the provided 5/16"-18 x 1-1/4" bolts with lock washers, flat washers, and 3/8" spacers. The C6 uses the two pan bolts directly behind the selector shaft. **Fig. 9**

**Step 9:** Remove the first 5/8"-18 jam nut (15/16" wrench size) and one of the internal tooth lock washers from the cable. Install the cable into the lower cable mounting bracket, and then reinstall the lock washer and jam nut onto the cable.

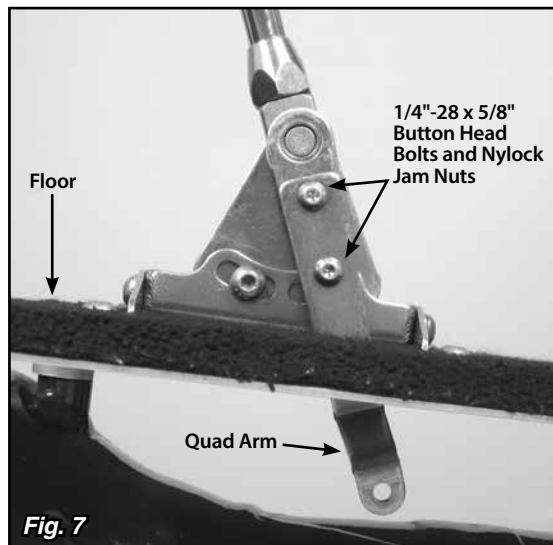


Fig. 7

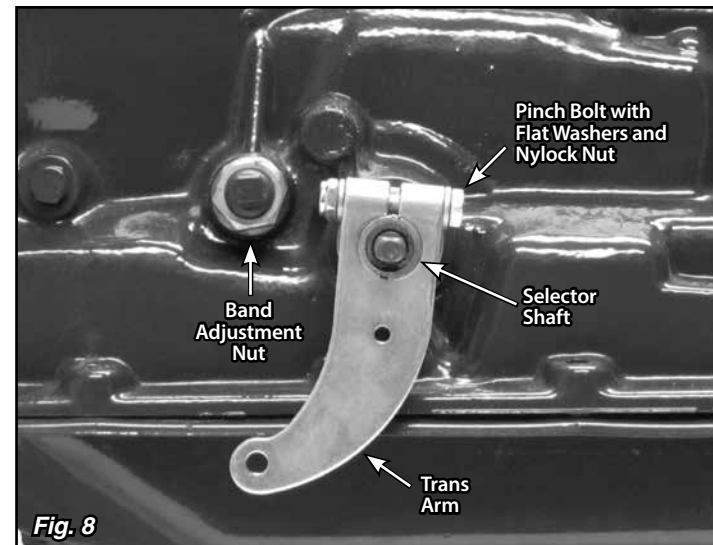


Fig. 8

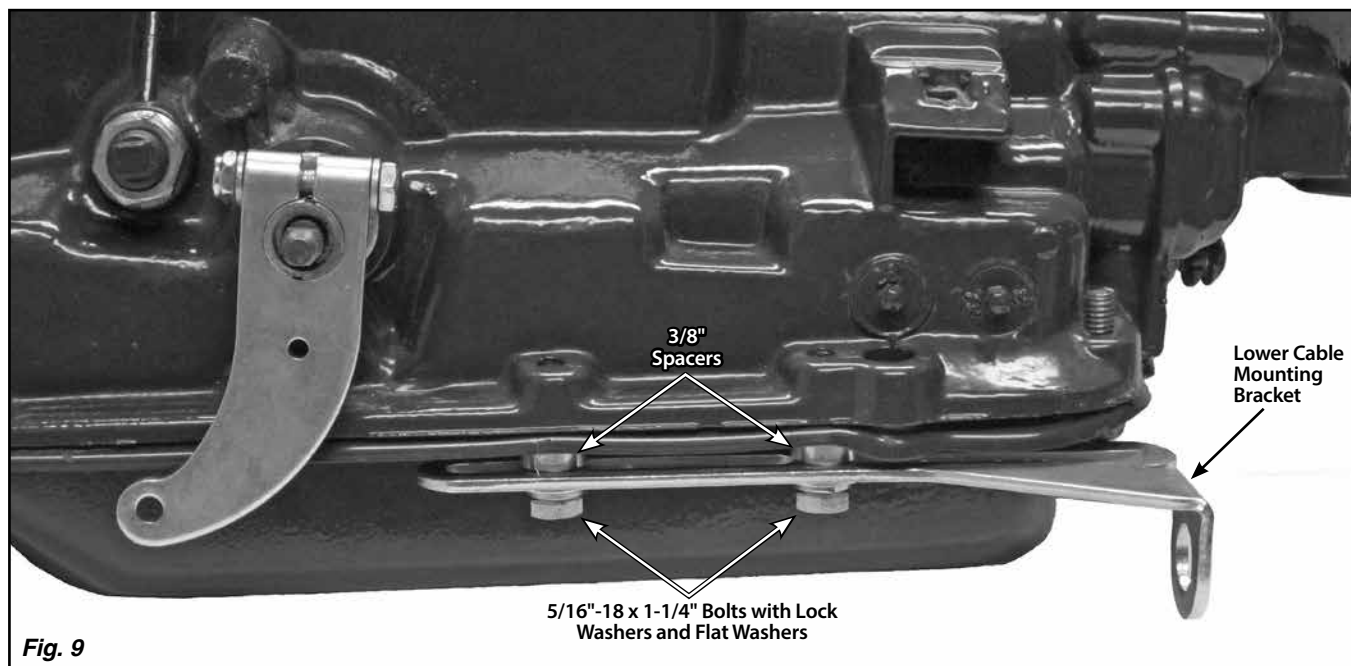


Fig. 9

**Step 10:** Make sure that the 1/4"-28 jam nuts are installed on each end of the cable. Then, install the rod ends onto the cable, threading them on approximately halfway. Do not tighten the jam nuts against the rod ends yet.

**Step 11:** Make sure that the shifter and the transmission are both in Park. Attach the rod end at the transmission to the trans arm using a 1/4"-28 x 1" button head bolt, flat washer, rod end spacer, and nylock nut. The rod end will be positioned on the outside of the trans arm, away from the transmission. The rod end spacer goes in between the rod end and the trans arm. The button head bolt can be installed from either direction, but make sure the rod end is sandwiched between the flat washer and the rod end spacer. **Fig. 10 & 11**

**Step 12:** Route the cable up to the shifter and attach the other rod end to the quad arm using a 1/4"-28 x 1" button head bolt, flat washer, and nylock nut. **Fig. 12** The button head bolt can be installed from either direction, but make sure the rod end is sandwiched between the quad arm and the flat washer. When routing the cable, make sure that it is not touching the exhaust or any moving parts. The cable should be routed as smoothly as possible without any sharp bends.

**Step 13:** Position the upper cable mounting bracket up against the bottom of the floor and next to the cable, aligned with the retaining groove on the cable. Align the upper cable mounting bracket with the quad arm, where the cable can push and pull in a smooth motion. **The location of the upper cable mounting bracket is an important factor in how smoothly the shifter operates, so make sure it is aligned correctly.**

**Step 13: (continued)** Determine how the cable clamp should be oriented on the upper cable mounting bracket and which bolt hole should be used for the best alignment with the quad arm. The cable clamp can be installed with the bolt above or below the cable. Insert the 5/16"-24 x 1" button head bolt into the cable clamp, and position the cable clamp on the cable, making sure that the bolt is seated in the retaining groove. **Fig. 13**

Install the cable clamp and 5/16"-24 x 1" button head bolt onto the upper cable mounting bracket and secure with a nylock nut. **Fig. 14**

**Step 14:** Make sure that the location chosen for the cable clamp on the upper cable mounting bracket will allow the cable to go straight to the hole in the quad arm without binding at any point in the shifter travel. Before drilling the bolt holes in the floor, be sure everything is mocked up correctly and if possible, clamp the upper cable mounting bracket in place and check operation of the shifter. Mark the center of the holes, center punch the marks, and drill both holes using a 5/16" drill bit.

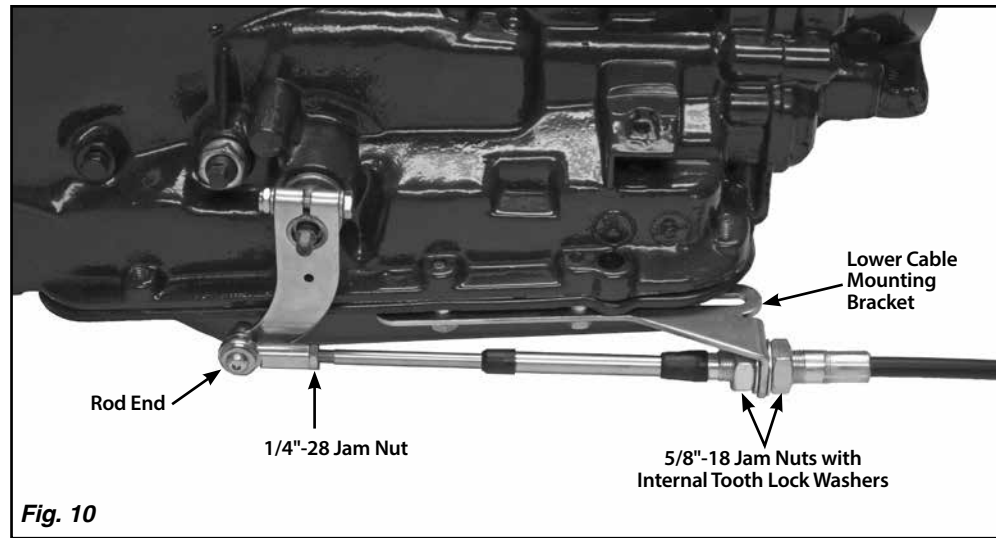
**Step 15:** Mount the upper cable mounting bracket to the floor using the 5/16"-24 x 1/2" button head bolts and nylock jam nuts. **Fig. 15**

**Step 16:** Check the adjustment of the shifter by placing the shifter lever all the way forward into Park. Make sure that the release button still moves up and down freely. The release button should be flush with the knob in Park and Neutral. In Reverse, you cannot pull the lever back into Neutral without depressing the release button.

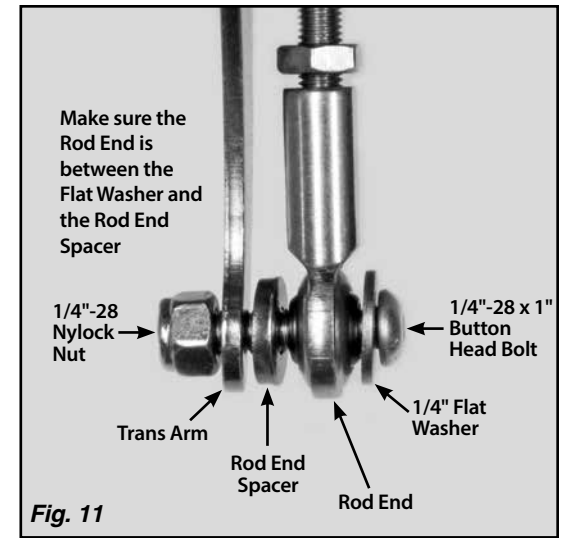
While the shifter is in Park, make sure the transmission is firmly in the Park detent, with no tension on the cable. You can verify that there is no tension on the cable by removing the 1/4"-28 x 1" bolt with nylock nut that attaches the rod end to the quad lever or trans gear lever at either end of the cable. Make sure the hole in the rod end exactly aligns with the hole in the quad lever or trans gear lever. The bolt should pass freely through both holes at the same time without binding. Do not force the holes to line up.

If the holes are not aligned, use the 5/8"-18 jam nuts at the lower cable mounting bracket to get the adjustment close. Then, you can fine-tune it by adjusting the rod ends until you can slide the bolt in and out without putting tension on the cable. Make sure that the quad lever and trans gear lever do not move during the adjustment procedure. Use this adjustment routine until the bolts will pass freely in and out of both of the rod ends and the quad lever and trans gear lever. Reinstall the 1/4"-28 nylock nuts and the flat washers onto the bolts and tighten.

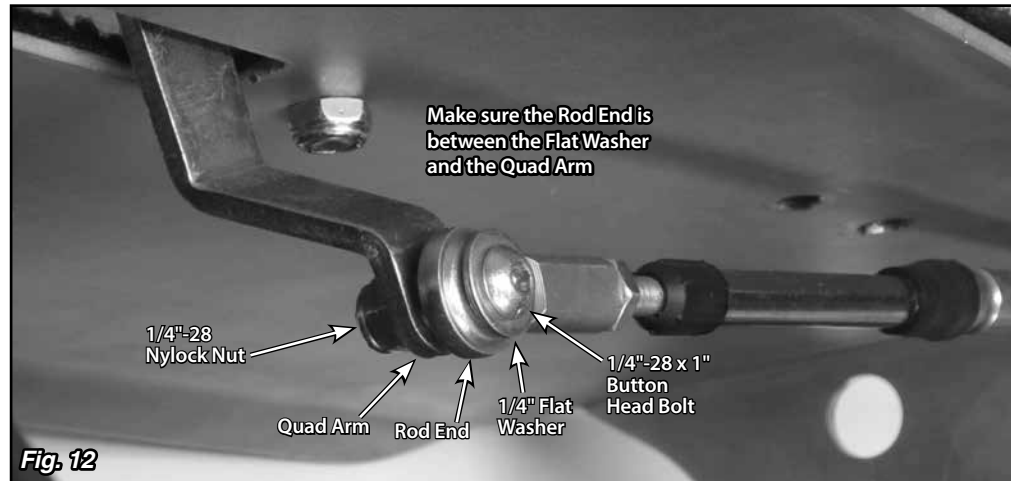
Once you have the shifter adjusted correctly, tighten the 1/4"-28 jam nuts on the ends of the cable, and the 5/8"-18 jam nuts at the lower cable mounting bracket.



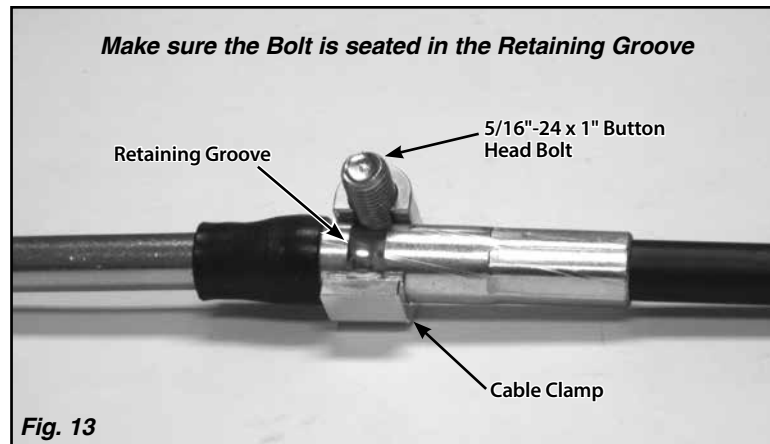
**Fig. 10**



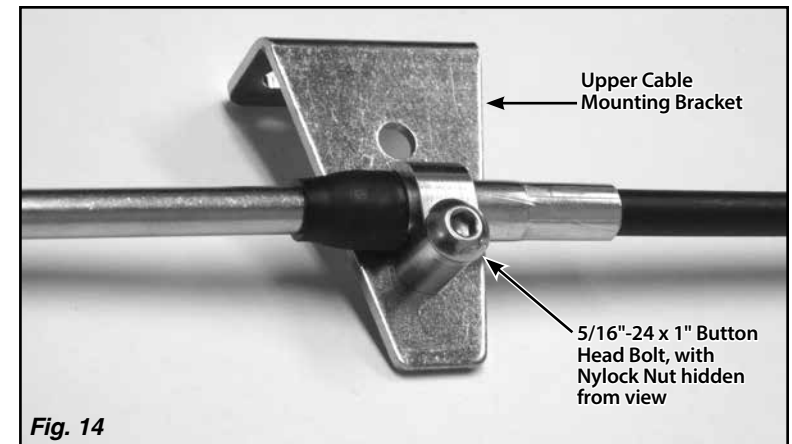
**Fig. 11**



**Fig. 12**



**Fig. 13**



**Fig. 14**

## Neutral Safety Switch Adjustment and Wiring

**Step 17:** For the neutral safety switch to function properly, the shifter linkage must be adjusted correctly. Do not attempt to adjust the neutral safety switch unless you have completed **Step 16**.

*The Lokar neutral safety switch is a simple on/off, non-directional switch. The switch passes current (turns on) when the ball is pushed in. It does not pass current (turns off) when the ball is out at its at-rest position.*

Double check to make sure that the bolts in the curved, slotted holes in the **left** side of the floor mount mounting bracket are tight.

**Step 18:** Remove the neutral safety switch and washer (**Fig. 16**) from the right side of the shifter using a 7/8" wrench or socket.

**Step 19:** Loosen, but do not remove, the two 5/16"-24 x 3/8" button head bolts that connect the right side of the floor mount mounting bracket to the switch plate (the bolts in the curved, slotted holes). **Fig. 17**

**WARNING:** Before taking the shifter out of Park, be sure that the vehicle's tires are blocked and the parking brake is set to avoid movement of the vehicle.

**Step 20:** Put the shifter into Reverse. Reposition the switch plate so that the hole in the switch plate lines up with the center groove in the shifter body. **Fig. 17** Screw the provided aluminum adjuster plug into the neutral safety switch opening. Wiggling the switch plate slightly forward and back while you are screwing the aluminum adjuster plug in will help get the shifter body centered on the adjuster plug. **Fig. 18**

**Step 21:** Retighten the two 5/16"-24 x 3/8" button head bolts that attach the right side of the floor mount mounting bracket to the switch plate.

**Step 22:** Remove the aluminum adjuster plug, and reinstall the neutral safety switch and washer onto the shifter. Test for continuity by connecting an ohmmeter lead to each stud on the neutral safety switch. When adjusted correctly, you will only have continuity between the two switch studs when the shifter is in Park or Neutral. Continuity in any other gear requires readjustment of the neutral safety switch or the shifter.

**Step 23:** Connect the neutral safety switch between your ignition switch and starter circuits. Check your wiring harness:

- **If your fuse panel has (2) connections for a neutral safety switch**, run a #12 (or heavier) stranded wire from these terminals in your fuse panel to the (2) terminals on the neutral safety switch. That completes the Neutral Safety Switch wiring.
- **If your fuse panel does not have neutral safety switch connections**, locate the wire going from the ignition switch to the starter. If GM color codes are used, this wire will usually be purple. After locating the wire, disconnect it from the starter. It must be cut and routed from the ignition switch to one of the neutral safety switch terminals, and from the other neutral safety switch terminal to the same stud on the starter where the original wire was removed. If the wire must be lengthened, be sure to use wire that is at least the same size or larger than the original.

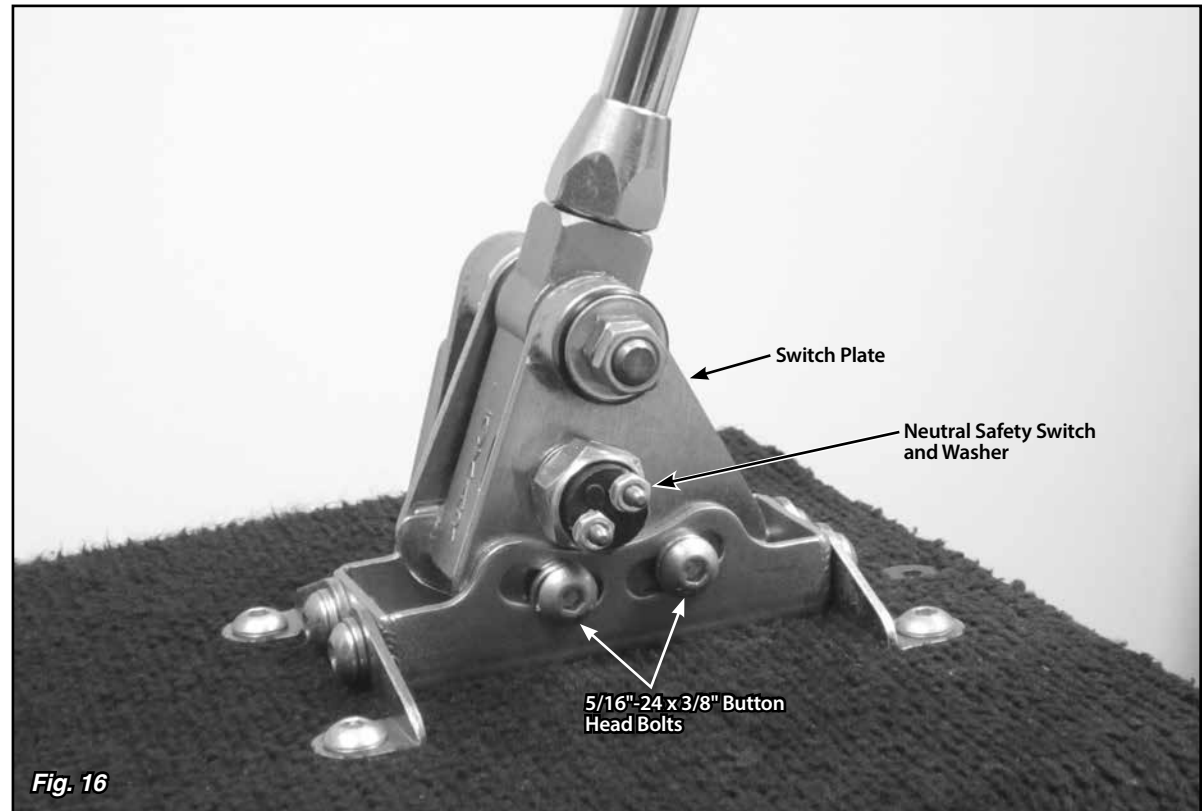
**Step 24:** Reconnect the negative battery cable and check operation. Make sure that the engine will not start in Reverse or a drive gear. If it does, follow the neutral safety switch adjustment procedure again. If your car should ever start in any gear other than Park or Neutral, please readjust the neutral safety switch accordingly. Tighten all brackets and bolts correctly and securely and there should be no movement or maladjustment. If you have any questions after following this procedure, please call Lokar Technical Support.

**Step 25:** Once the installation is completely finished and the neutral safety switch is adjusted, remove each of the 5/16"-24 x 3/8" button head bolts from the curved, slotted holes in the floor mount mounting bracket one at a time, apply blue thread locking compound to the threads, and reinstall.

**Fig. 19** shows a completed installation.

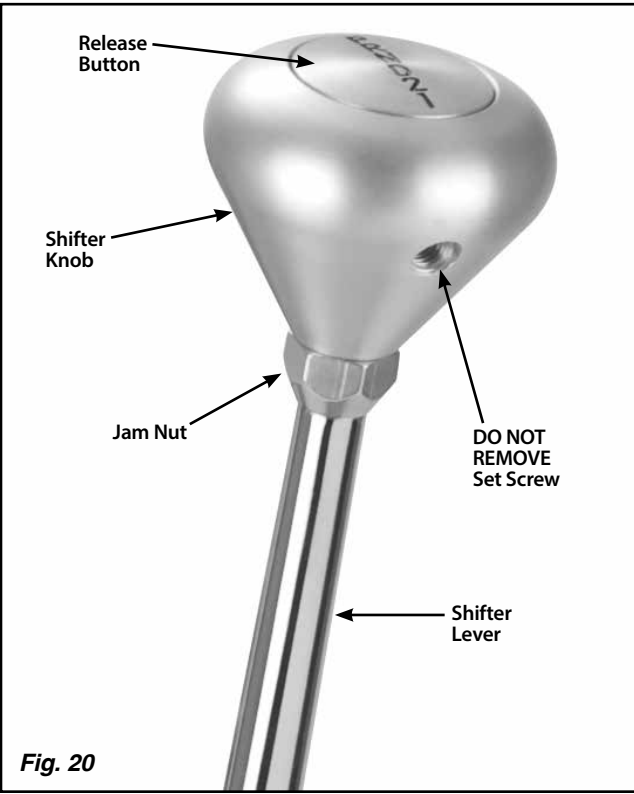
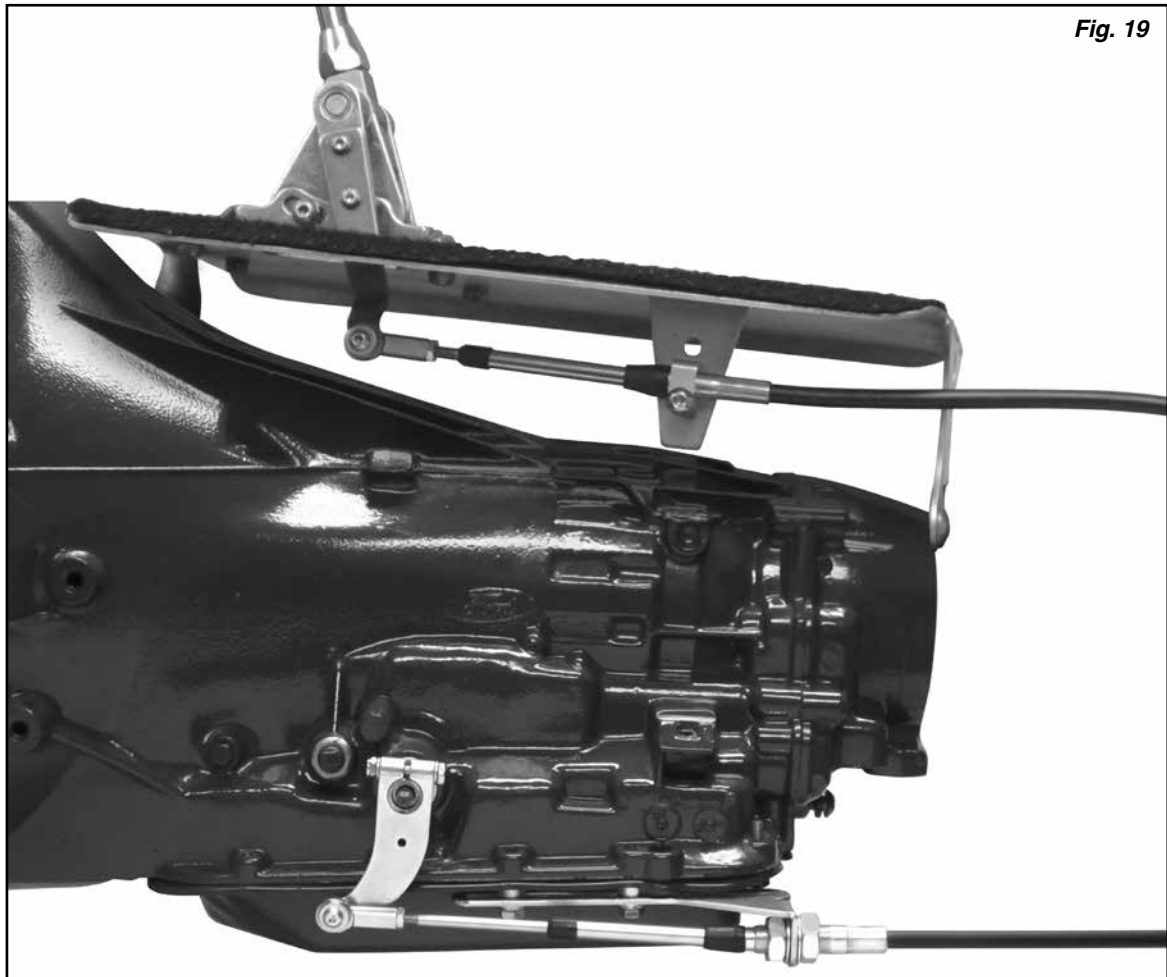
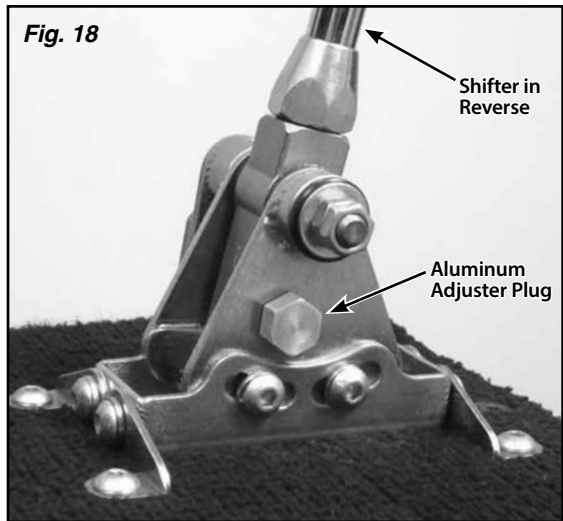
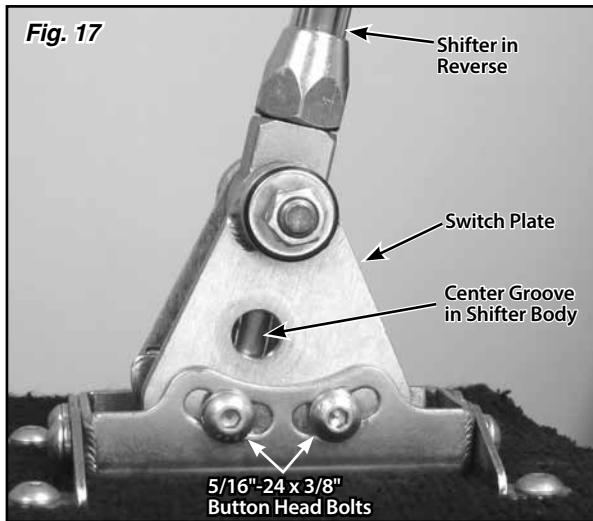


**Fig. 15**



**Fig. 16**





## Lokar Shifter Knob Removal Instructions (For Shifters Manufactured 1995 and Later)

*For shifters manufactured 1994 and earlier, please contact Lokar for assistance.*

**To Remove Shifter Knob:**

- Step 1:** Make sure the shifter is all the way forward in Park.
- Step 2:** Loosen the jam nut below the shifter knob. **DO NOT** loosen or remove the set screw that is in the knob. **Fig. 20**
- Step 3:** Turn the shifter knob counter-clockwise to remove.

**To Install Shifter Knob:**

- Step 1:** Make sure the jam nut is still in place on the shifter lever.
- Step 2:** Screw the shifter knob onto the shifter lever until the release button comes up flush with the top of the shifter knob.
- Step 3:** Tighten the jam nut up against the bottom of the shifter knob.
- Step 4:** Check to make sure that depressing the release button allows the shifter lever to be moved, and make sure the shifter lever still locks in Park and Neutral. If the shifter will not come out of "Park" with the release button fully depressed, tighten the knob one turn and check it again. If the shifter does not lock in "Park", loosen the knob one turn and check it again.