



QUALITY... PLAIN & SIMPLE®

Billet Aluminum Throttle & Kickdown Cable Mounting Bracket for Street Demon® Installation Instructions

General Installation Notes:

Please read these instructions completely before beginning the installation. If you have any questions please call.

Before beginning the installation, disconnect the negative battery cable and use wheel chocks to block the vehicle's wheels.

Make sure the engine, transmission, body and frame are properly grounded. We recommend using anti-seize lubricant on all aluminum threads.

Refer to Fig. 1 and Fig. 2 for the component names.

This Cable Mounting Bracket is designed to be used with a Lokar Throttle Cable and Kickdown Cable (if applicable).

Step 1: If the carburetor has already been installed onto the intake manifold, remove the two rear carburetor bolts or studs. If the carburetor has not been installed, install the carburetor base gasket and carburetor onto the intake manifold, but do not install the two rear bolts.

Step 2: If you **are not** installing a Street Demon® Throttle Position Sensor (TPS), skip to **Step 3**.

If you **are** installing a Street Demon® TPS (not included), install the TPS kit onto the carburetor following the instructions that were provided with the TPS kit.

Step 3: Place the aluminum linkage bracket onto the rear of the carburetor base, and install the two 5/16"-18 x 1-1/2" socket head bolts that are supplied with the Lokar Cable Mounting Bracket. **NOTE:** If you are using a spacer under the carburetor, you will need to supply new bolts that are longer by the same amount as the spacer thickness. Example: 1/2" spacer requires $1-1/2" + 1/2" = 2"$ bolt. **Fig. 3 & Fig. 4**

Step 4: Connect the inner and outer springs to the small hole in the aluminum linkage bracket and to the return spring hole on the carburetor throttle lever. **Fig. 5 & Fig. 6**

Step 5: Install the Lokar Throttle Cable and Kickdown Cable (if applicable) according to the instructions included with those parts. See **Fig. 7** for a completed installation with a Lokar Throttle Cable and Kickdown Cable, and **Fig. 8** for a completed installation with a Lokar Throttle Cable and a Street Demon® Throttle Position Sensor.

Billet Aluminum Throttle & Kickdown Cable Mounting Bracket for Street Demon® Installation Instructions

Building American Quality... With A Lifetime Warranty!®

TOLL FREE 1-877-469-7440 • tech@lokar.com • www.lokar.com

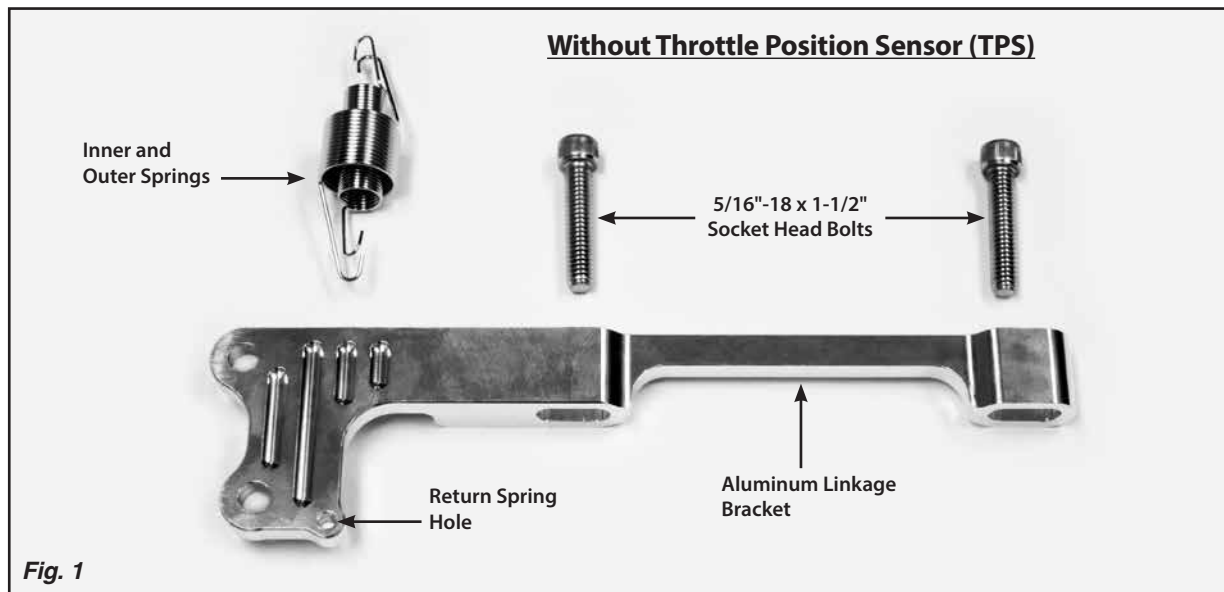

Fig. 1

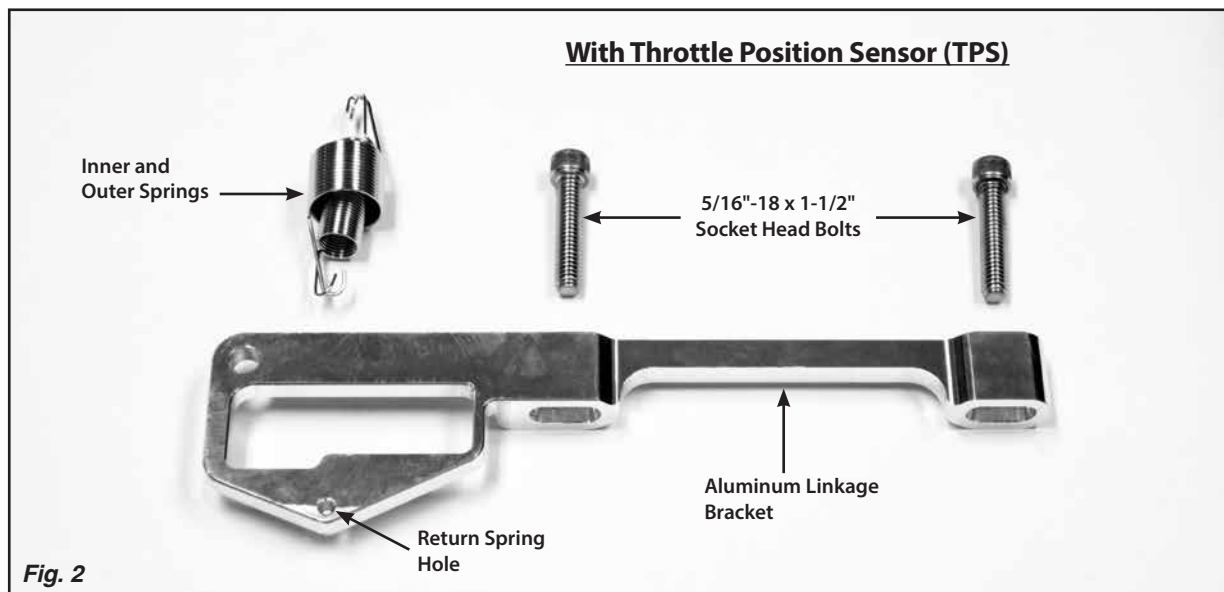

Fig. 2

Billet Aluminum Throttle & Kickdown Cable Mounting Bracket for Street Demon® Installation Instructions

