

General Installation Notes:

Please read these instructions completely before beginning the installation. If you have any questions please call.

Before beginning the installation, disconnect the negative battery cable and use wheel chocks to block the vehicle's wheels.

Make sure the engine, transmission, body and frame are properly grounded. We recommend using anti-seize lubricant on all aluminum threads.

Refer to Fig. 1, Fig. 4, and Fig. 6 for the component names.

Brake Pedal Arm Installation

Step 1: Remove any existing brake and (if applicable) clutch pedals, along with the pedal axle or support pin that they are hanging from. Remove any existing nylon flanged bearings from the pedal hanger bracket.

Remove the clevis from your existing master cylinder pushrod.

Step 2: Remove the cotter pin, clevis pin and brake arm clevis from the new brake arm.

Step 3: Install the new brake arm clevis onto your existing master cylinder pushrod.

Step 4: Insert the new nylon flanged bearings into the pedal hanger bracket.

Step 5: Insert a 1/2" sleeve bearing into each of the nylon flanged bearings.

Step 6: If you have manual brakes, the clevis should be connected to the upper hole in the brake arm. If you have power brakes, the clevis should be connected to the lower hole in the brake arm.

Align the holes in the brake arm clevis with the correct hole in the brake arm and install the clevis pin, 3/8" AN washer, and cotter pin.

Step 7: Install a 7/16" black washer onto the 7/16"-14 x 4" hex bolt. Position the brake arm inside the pedal hanger bracket. **Note, 1967-1972 Chevelle: Make sure the Chevelle Spacer is in position on the left (driver's) side of the brake arm.** Install the bolt from either side, pushing it through one side of the pedal hanger bracket and into the brake arm.

As you push the bolt through the opposite side of the pedal hanger bracket, make sure the 1/2" sleeve bearing and nylon flanged bearing don't get pushed out by the bolt. If they do, push them back in once the bolt is fully inserted in the pedal hanger.

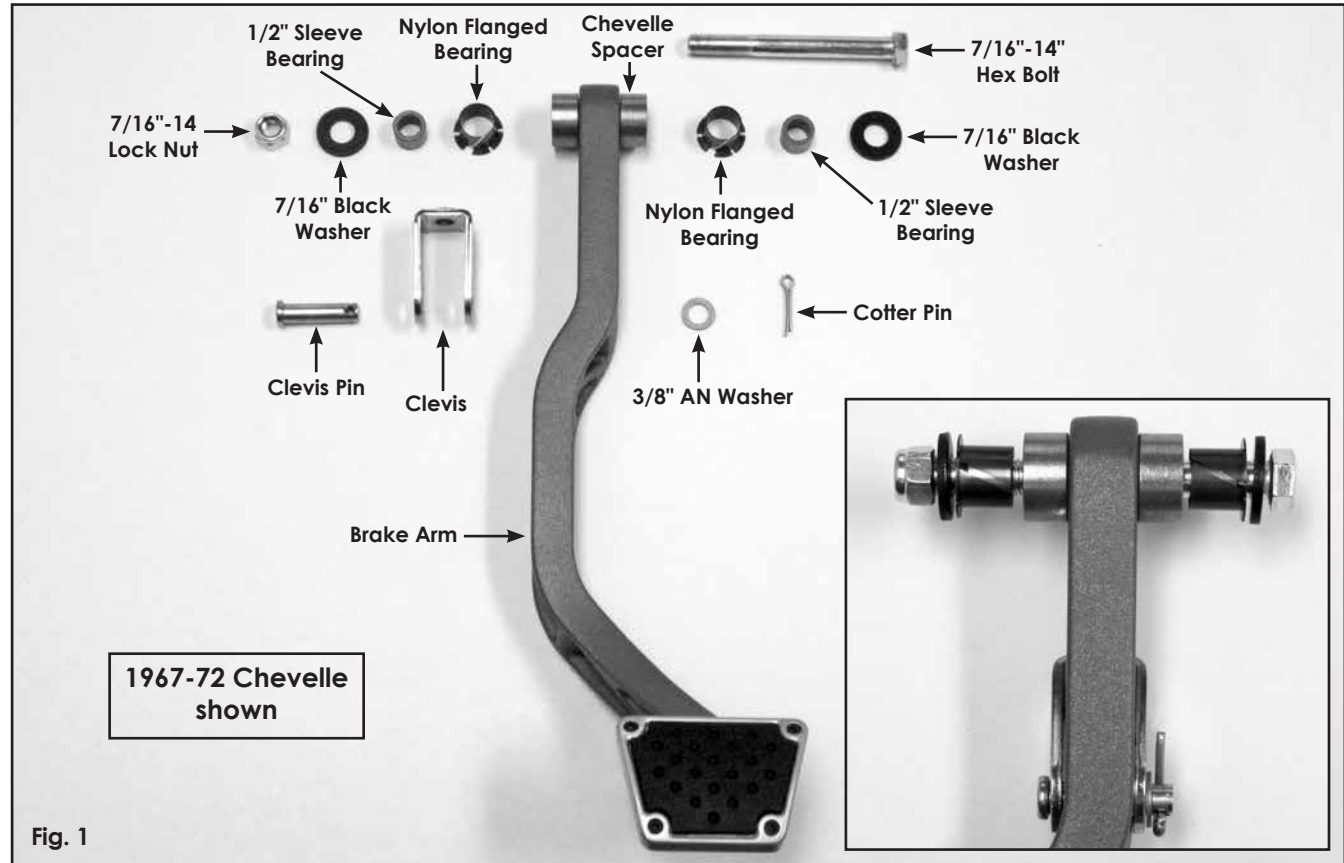

Fig. 1

Step 8: Place the other 7/16" black washer onto the end of the bolt. Install the 7/16"-14 lock nut onto the bolt. Snug it down, and then (if needed) loosen the nut just enough so that the brake arm will swing freely.

Step 9: Adjust the height of the brake pedal as needed. Tighten the jam nut on your master cylinder pushrod.

Step 10: Adjust your brake light switch.

For exploded and assembled views:

- 1967-72 Chevelle, see Fig. 1
- 1967-69 Camaro, 1964-66 Chevelle, 1968-74 Nova, see Fig. 2 and Fig. 3

**CLAYTON
MACHINE
WORKS**

Muscle Car
Pedals Installation
Instructions for
1964-72 Chevelle,
1967-69 Camaro,
and 1968-74 Nova



865 - 824 - 9778

Muscle Car Pedals Installation Instructions for 1964-72 Chevelle, 1967-69 Camaro, and 1968-74 Nova

Brake and Clutch Pedal Arm Installation

Step 1: Remove any existing brake and (if applicable) clutch pedals, along with the pedal axle or support pin that they are hanging from. Remove any existing nylon flanged bearings from the pedal hanger bracket.

Remove the clevis from your existing master cylinder pushrod.

Step 2: Remove the cotter pin, clevis pin and clevis from the new brake arm.

Step 3: Install the new clevis onto your existing master cylinder pushrod.

Step 4: Insert the new nylon flanged bearings into the pedal hanger bracket.

Step 5: Insert a 1/2" sleeve bearing into each of the nylon flanged bearings.

Step 6: If you have manual brakes, the clevis should be connected to the upper hole in the brake arm. If you have power brakes, the clevis should be connected to the lower hole in the brake arm.

Align the holes in the clevis with the correct hole in the brake arm. Install the clevis pin, 3/8" AN washer, and cotter pin.

Step 7: Install a 7/16" black washer onto the 7/16"-14 x 5-1/2" hex bolt. Position the brake arm inside the pedal hanger bracket. **Note, 1967-1972 Chevelle: Make sure the Chevelle Spacer is in position on the left (driver's) side of the brake arm.** Install the bolt from the right (passenger's) side, pushing it through the side of the pedal hanger bracket and into the brake arm.

As you push the bolt through the opposite side of the pedal hanger bracket, make sure the 1/2" sleeve bearing and nylon flanged bearing don't get pushed out by the bolt. If they do, push them back in once the bolt is fully inserted in the pedal hanger.

Step 8, 1967-1972 Chevelle: Install the clutch arm onto the bolt.

1967-69 Camaro/Firebird, 1964-1966 Chevelle, 1968-74 Nova: Install the clutch bushing onto the bolt and slide it up next to the pedal hanger, against the nylon flanged bearing. Then, install a Teflon washer and the clutch arm onto the bolt.

Step 9: Install a Teflon washer and a 7/16" black washer onto the bolt, and install and tighten the 7/16"-14 lock nut onto the bolt. If the clutch pedal feels stiff, back the nut off just enough so that the clutch arm will swing freely.

Step 10: Adjust the height of the brake pedal as needed. Tighten the jam nut on your master cylinder pushrod.

Step 11: Connect your original clutch pushrod to the clutch arm.

Step 12: Adjust your brake light switch.

For exploded and assembled views:

- **1967-72 Chevelle, see Fig. 4 and Fig. 5**
- **1967-69 Camaro, 1964-66 Chevelle, 1968-74 Nova, see Fig. 6 and Fig. 7**

