



QUALITY... PLAIN & SIMPLE®

Eliminator Floor Mount Throttle Pedal Installation Instructions

General Installation Notes:

Please read these instructions completely before beginning the installation. If you have any questions, please call.

Before beginning the installation, disconnect the negative battery cable and use wheel chocks to block the vehicle's wheels.

Make sure the engine, transmission, body and frame are properly grounded. We recommend using anti-seize lubricant on all aluminum threads.

The Lokar Eliminator Floor Mount Throttle Pedal is designed to work with a Lokar Throttle Cable. Most applications will require a 36" Throttle Cable. Vehicles equipped with a fuel injected GM LS, Ram Jet, or Vortec engine will require a 48" Throttle Cable.

Step 1: Determine your desired mounting location. This Throttle Pedal is designed to be mounted on the angled toe board just below the vertical firewall, **NOT** on the horizontal part of the floor. **Fig. 1** The bottom edge of the pedal pad should be parallel to the horizontal part of the floor. Make sure that the location of the pedal bracket, Throttle Cable, and cable pull arm will not interfere with any other components such as brake or fuel lines, clutch linkage, wiring, or exhaust. **Fig. 2**

NOTE: If the cable pull arm creates interference because it extends too far into the engine compartment, Lokar has a 1/2" Throttle Pedal Spacer available that may be a solution. Part # GPS-6016 (brushed) or XGPS-6016 (black).

Step 2: Remove the pedal pad from the throttle pedal assembly. Be careful to keep the assembly together while the pedal pad is removed. Lay the pedal pad on the toe board at the desired location and angle. Check the pedal position for comfort. Mark the position of the pedal pad on the left side and the bottom of the pedal pad using tape, a scribe or a marker. **Fig. 3**

Step 3: Remove the pedal pad from the toe board.

Step 4: Use the back side of the pedal bracket as a template. Position it flat on the toe board with the left edge aligned with your vertical mark, and the bottom left corner 3/4" above your bottom mark. **Fig. 4** Mark the four (4) bolt holes using a center punch or marker. Trace the inside of the rectangular hole onto the toe board.

Eliminator Floor Mount Throttle Pedal Installation Instructions

Building American Quality... With A Lifetime Warranty!®

TOLL FREE 1-877-469-7440 • tech@lokar.com • www.lokar.com

Step 5: Verify again that nothing is going to interfere with the pedal bracket and that nothing will be damaged when drilling/cutting the holes. Use a 3/16" drill bit to drill out all four (4) bolt holes.

The best way to cut out the center rectangle is to drill a hole in each of the 4 corners in the rectangle. Then, cut from hole to hole with a die grinder cutoff wheel.

Step 6: Test fit the pedal assembly for proper location, clearance and angle.

Step 7: Remove the triangular splined bearing block from the cable pull shaft. **Fig. 5**

Step 8: Temporarily install the pedal assembly and bracket onto the toe board, using only two (2) of the four #10-32 x 3/4" button head bolts and nylock nuts, installed in opposite corners, with the cable bracket in place. Snug the nuts down just tight enough to hold the assembly in place temporarily.

Step 9: The idle and wide open throttle pedal stops are button head bolts with jam nuts that are located on the cable pull arm. The one on the top side is the idle stop, and the one on the bottom is the wide open throttle stop. Adjust the idle stop out so that the measurement from the cable pull arm to the top of the button head is about 1/4". **Fig. 6**

Step 10: Raise the cable pull arm all the way up until the idle stop makes contact, and reinstall the triangular splined bearing block with the long flat side at the angle you want the pedal pad to be at idle.

Step 11: Remove the pedal assembly from the vehicle and reinstall the pedal pad onto the pedal assembly.

Step 12: Re-install the complete throttle pedal assembly with the pedal bracket and all four mounting bolts. Pull the pedal pad all the way up against the idle stop, and test for position and comfort. Readjust if necessary. Once you are satisfied with the position of the pedal pad, tighten the jam nut on the idle stop.

Step 13: Attach the throttle cable housing to the pedal bracket, following the Throttle Cable installation instructions. Install the throttle cable inner wire, and attach the clevis to the cable pull arm. **Fig. 7** For normal sheetmetal floors, connect the clevis to the inner hole (closest to the floor). For fiberglass or other thick floors, connect the clevis to the outermost hole in the cable pull arm.

Step 14: Adjust the Throttle Cable so that there is no tension on the inner wire at idle. Then, move the throttle to the wide open position and hold it there. Adjust the wide open throttle pedal stop (on the bottom side of the cable pull arm) out so that it touches, to prevent overstressing the pedal, cable, bracket and throttle linkage. Tighten the jam nut and release the throttle.

NOTE: If the pedal pad contacts the carpet or floor prematurely and prevents the throttle from reaching the wide open position, Lokar has a 1/2" Throttle Pedal Spacer available that will help. Part # GPS-6016 (brushed) or XGPS-6016 (black).

Step 15: Verify smooth operation with no binding. Verify that the idle and wide open throttle stops are adjusted correctly.

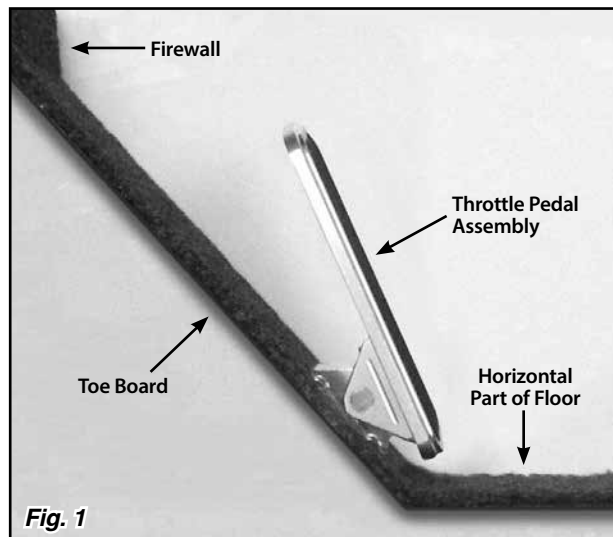

Fig. 1

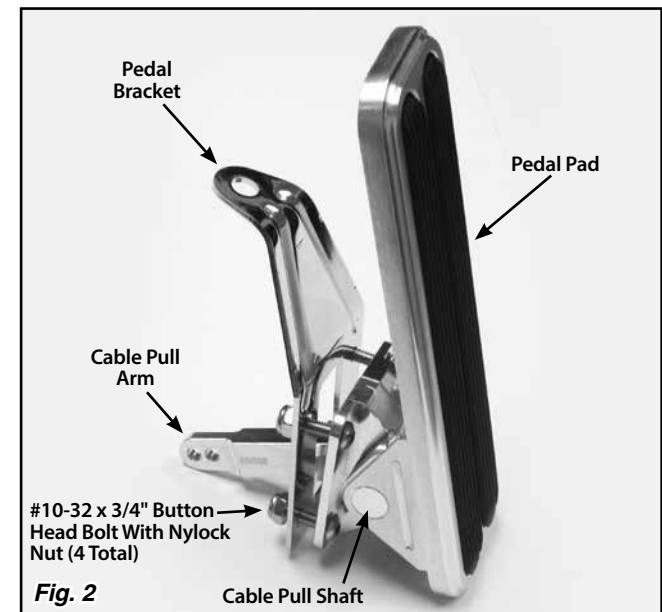
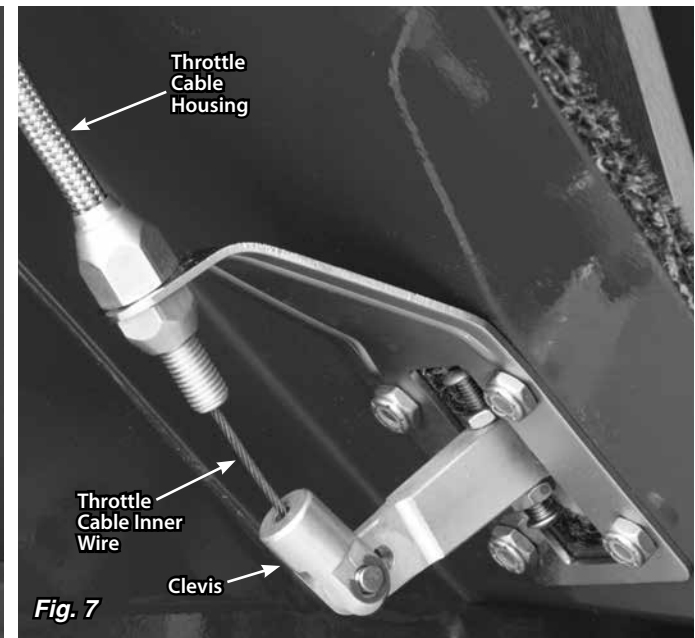
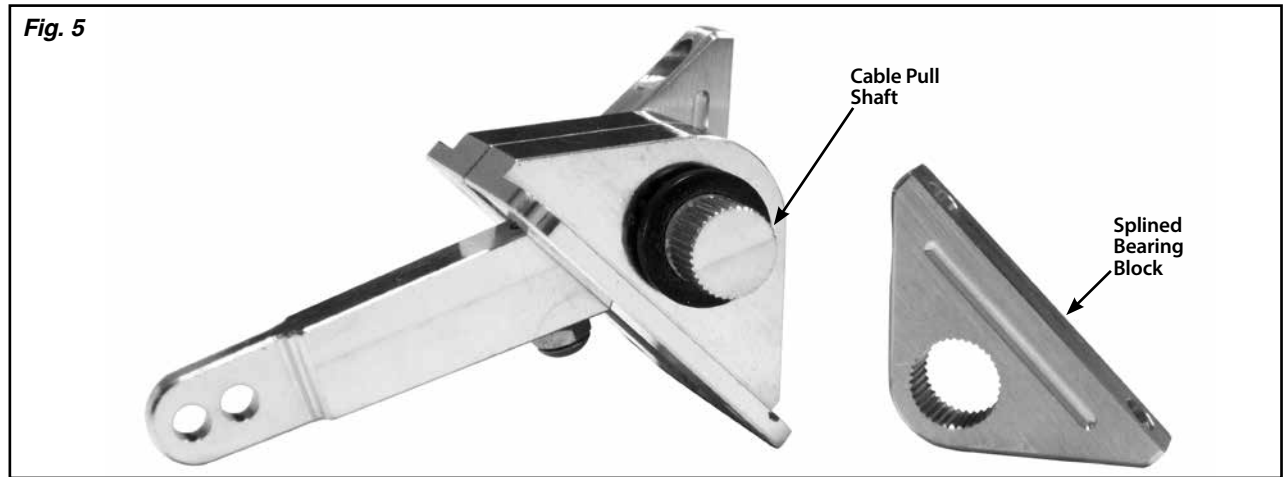
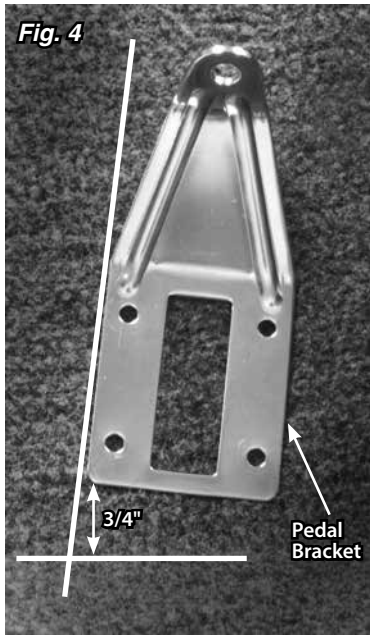
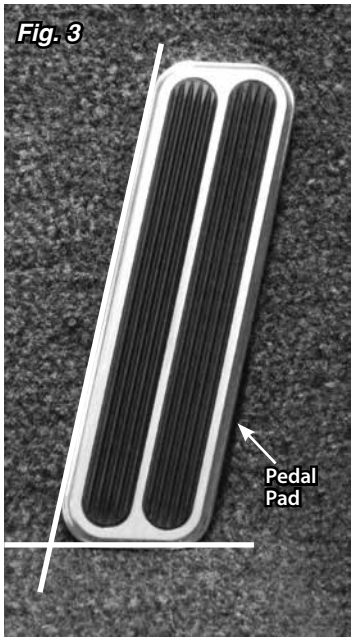

Fig. 2

Eliminator Floor Mount Throttle Pedal Installation Instructions



Throttle Cable Housing, Inner Wire, and Clevis shown above are not included with the Throttle Pedal.