



QUALITY... PLAIN & SIMPLE®

## Column Shift Linkage Installation Instructions For Ford AOD, 4R70W, and AODE

### General Installation Notes:

Please read these instructions completely before beginning the installation. If you have any questions, please call.

Before beginning the installation, disconnect the negative battery cable and use wheel chocks to block the vehicle's wheels.

Make sure the engine, transmission, body and frame are properly grounded.

**AOD applications also require the installation of a Lokar Kickdown Kit, available separately.**

The Lokar Column Shift Linkage is designed to work with GM style factory or aftermarket column shift steering columns. The stainless steel rod is designed to be cut-to-fit for individual applications. The kit comes with a 21" long rod. A 26" long rod is also available for purchase separately (Lokar part # ATA-1837). The Lokar Column Shift Linkage is designed with identical rod ends so that the hex connector can be used at either end of the stainless steel rod for clearance purposes.

Refer to Fig. 1, 2 and 3 for the part names.

**NOTE: It will be much easier to install the new selector shaft before the transmission is installed in the vehicle, if possible.**

The AOD (non-computer controlled) transmission has a Throttle Valve (T.V.) shaft that passes through the center of the selector shaft. Parts of these instructions and some of the photos will refer to the T.V. shaft, a T.V. lever, and a T.V. spring. **These parts are not present in an AODE or 4R70W transmission.**

**Step 1:** Put the shifter and the selector shaft on the transmission into the "Park" position. Remove any existing linkage from the selector shaft and from the steering column.

**Step 2: NOTE, AOD Only:** Remove the nut and T.V. lever from the T.V. shaft in the center of the selector shaft.

**NOTE, AODE and 4R70W Only:** Remove the bolt or nut from the center of the selector shaft, and remove the original trans arm.

**If the new Lokar Flange fits on your existing selector shaft, it is not necessary to replace the existing selector shaft. If you are only installing the Lokar Selector Shaft Flange and Arm and are not replacing the selector shaft, skip to Step 13.**

**Step 3:** Drain the transmission fluid and remove the transmission pan and filter.

**Step 4:** Remove the 1/8" diameter roll pin that is located just inside the pan rail on the boss that the selector shaft slides through. The pin protrudes about 1/8" beyond the boss. Use a pair of side cutters to grab the roll pin and pry the pin out using the case as your leverage point. **Fig. 4** If the roll pin has been pushed all the way in previously, you can use a small drill bit to grab the inside of the roll pin to pull it out.

# Column Shift Linkage Installation Instructions

## For Ford AOD, 4R70W, and AODE

Building American Quality... With A Lifetime Warranty!®

TOLL FREE 1-877-469-7440 • tech@lokar.com • www.lokar.com

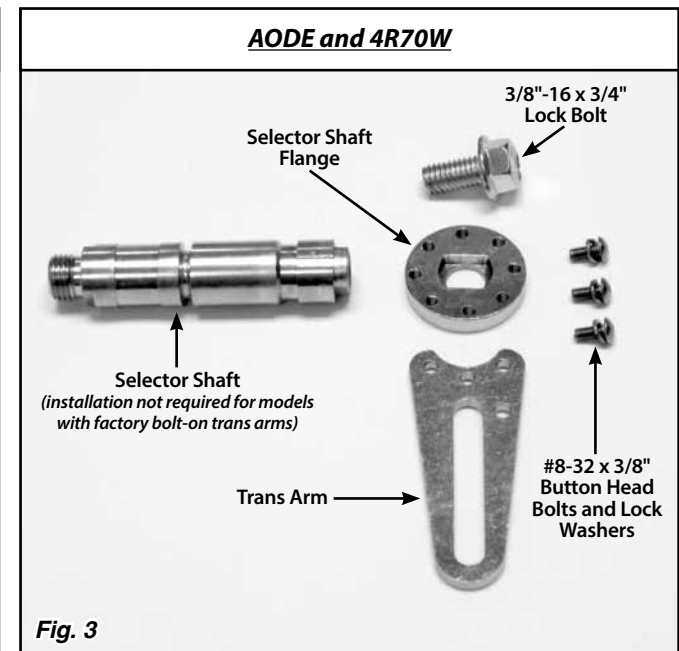
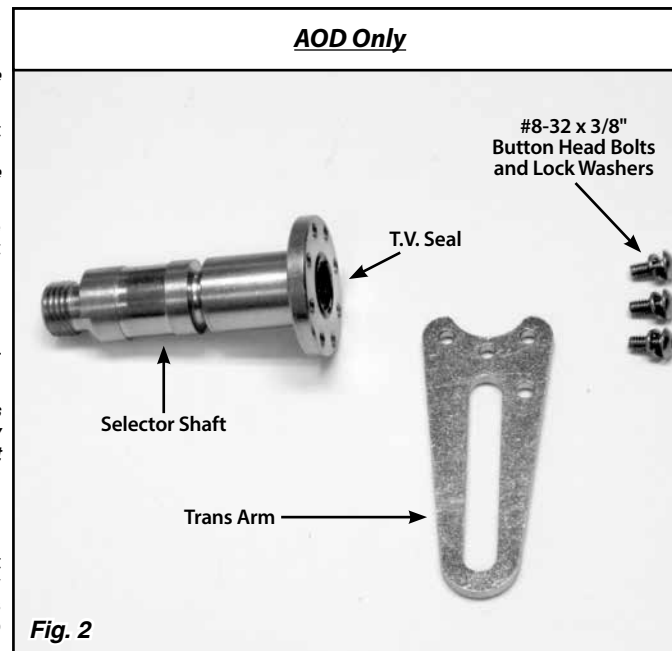
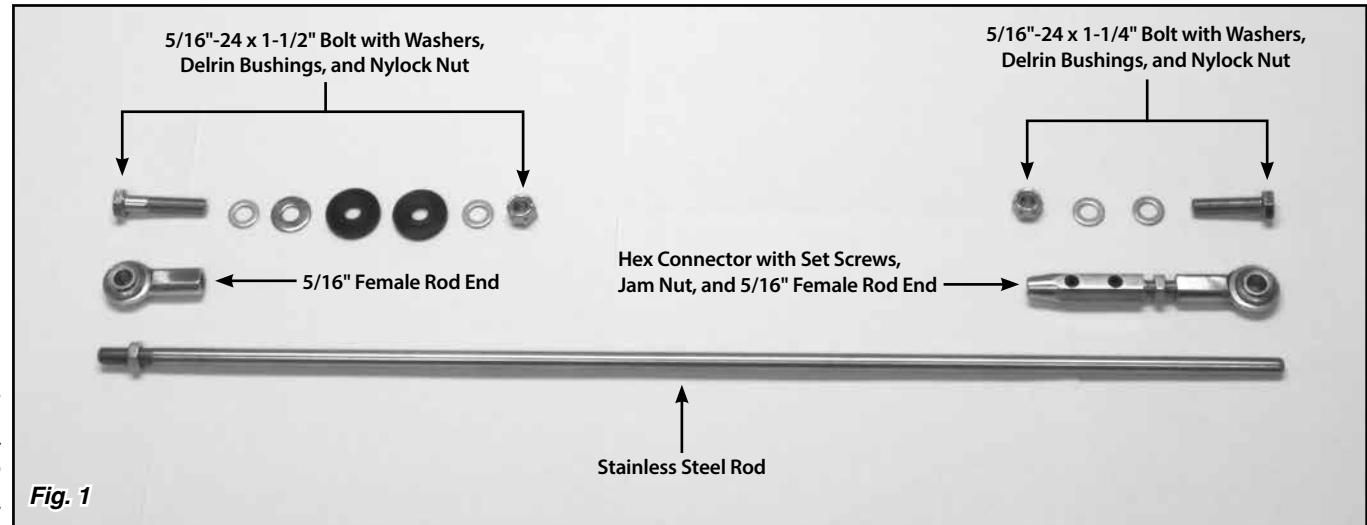

## Column Shift Linkage Installation Instructions for Ford AOD, 4R70W, and AODE

**Step 5:** Remove the roller spring that holds the gear selector plate in each gear position. **Fig. 5**

**Step 6. NOTE, AOD Only:** There is a small spring that keeps tension on the T.V. shaft. Make sure to pay attention to how this spring is positioned, because it will likely slip out of place during this step.

**All:** Move the gear selector plate all the way to the rear to put it into low gear. Hold the gear selector plate with a box end wrench or other tool to keep it from rotating, and unscrew the large nut from the end of the selector shaft. On the AOD transmission, the nut will still be retained by the T.V. shaft and will remain in the transmission. **Fig. 6 and Fig. 7**

**Step 7. NOTE, AODE and 4R70W Only:** Remove the Auto Trans Gear Position Sensor from the outside of the transmission case by removing the mounting bolts and sliding it off of the selector shaft.

**All:** Remove the old selector shaft from the transmission by sliding it out of the bore. The gear selector plate will stay in the transmission, and you may have to tap on it or lightly pry on it to get it separated from the selector shaft.

**Step 8:** Lubricate the selector shaft seal in the transmission and the new Lokar Selector Shaft with a small amount of transmission fluid or transmission assembly grease. On the AOD only, also lubricate the T.V. shaft seal that is inside the new selector shaft. **DO NOT** remove the T.V. shaft seal; it is not necessary to remove it for installation of the selector shaft.

Slide the Lokar Selector Shaft into the transmission. On AOD models, the T.V. shaft fits inside the Selector Shaft.

**Step 9:** Align the two flats on the new Selector Shaft with the flats on the gear selector plate in the transmission, and install the Selector Shaft into the gear selector plate. **Fig. 8** The gear selector plate has a pin attached to it that must be positioned in the groove on the piston that protrudes from the valve body. This pin needs to be in the groove before the large nut is tightened. **Fig. 9** Once the pin is in the groove, tighten the nut.

**NOTE, AOD Only:** If the T.V. spring slipped out of place, put the spring back into position as shown in **Fig. 10**. Also verify that the internal T.V. lever is aligned with the T.V. piston. With the external T.V. lever removed, it is possible for the T.V. shaft and internal lever to slide in too far, and the lever can get trapped between the T.V. piston and the valve body. **Fig. 6 and Fig. 10**

**Step 10:** Reinstall the roller spring that holds the gear selector plate in gear. **Fig. 11**

**Step 11:** Reinstall the 1/8" roll pin. It will align with the groove in the Selector Shaft. **DO NOT DRIVE THE ROLL PIN ALL THE WAY IN FLUSH WITH THE CASE!** It is important that the roll pin is sticking out beyond the casting so it can be removed if needed at another time. **Fig. 12**

**NOTE, AODE and 4R70W Only:** Reinstall the Auto Trans Gear Position Sensor onto the Selector Shaft and attach to the transmission case using the original bolts. Make sure the tabs on the inside of the sensor are aligned with the slots in the Selector Shaft.

**Step 12:** Rotate the gear selector plate all the way forward (clockwise) into the "Park" position.

**AOD shown in all photos below. AODE & 4R70W are similar.**

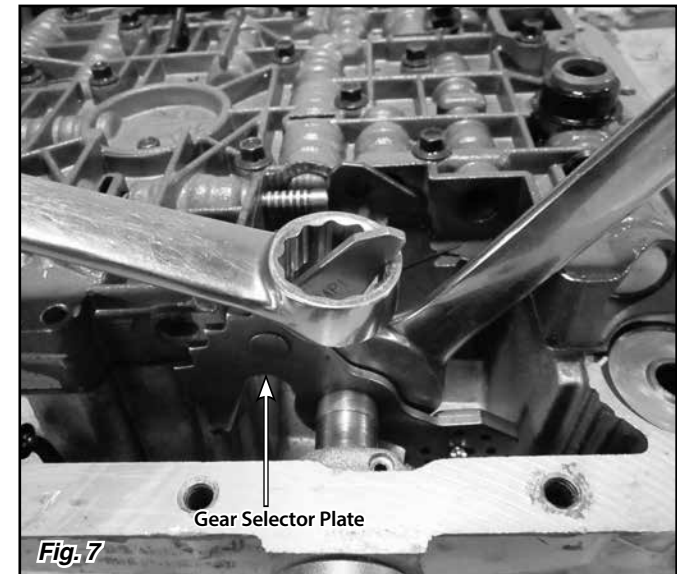
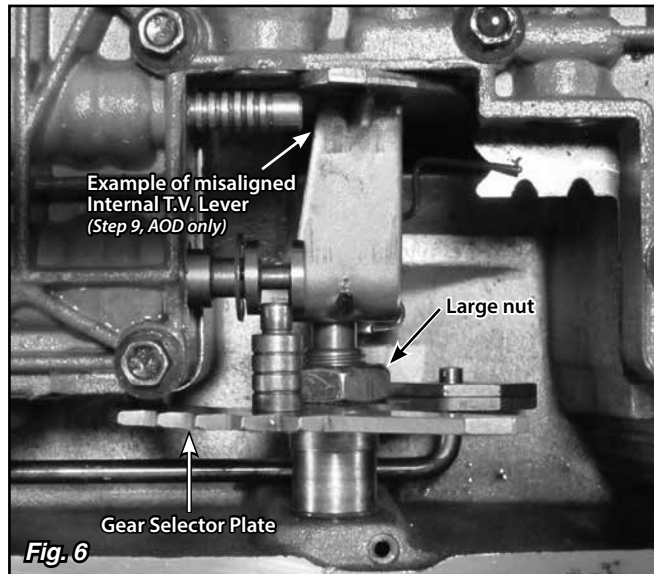
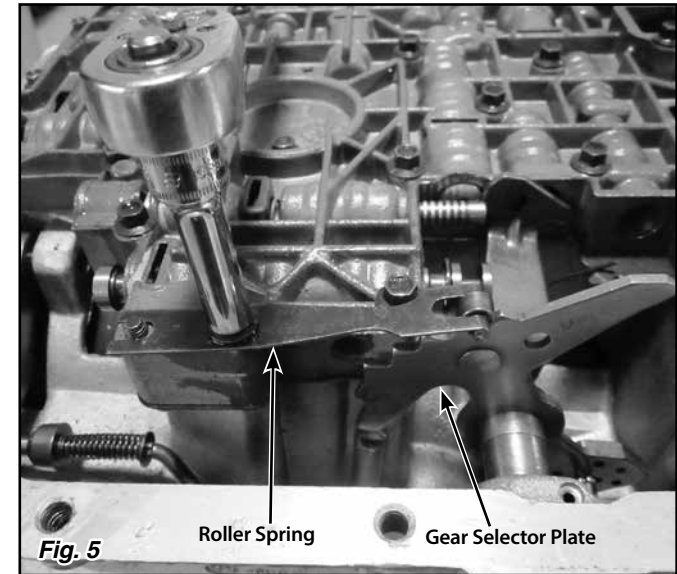
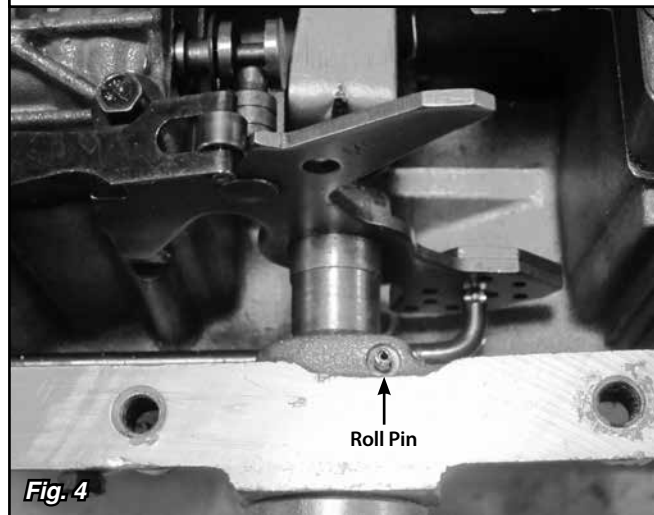

## Column Shift Linkage Installation Instructions for Ford AOD, 4R70W, and AODE

**Step 13: NOTE, AODE and 4R70W Only:** Install the new Lokar Flange onto the Selector Shaft. If using the original selector shaft, use the original nut or bolt to retain the flange. If using the Lokar Selector Shaft, install the supplied 3/8"-16 x 3/4" lock bolt into the Selector Shaft to retain the flange

**All:** Install the trans arm onto the new Selector Shaft or Flange using the three #8-32 x 3/8" button head bolts and lock washers. The trans arm should be installed at approximately the 7:30 position as a starting point with the transmission in "Park". **Fig. 13** The trans arm may need to be repositioned depending on your particular steering column. The 3/16" diameter hole that is part way up the trans arm next to the slot should be towards the back of the transmission. This hole is used with a Lokar Shift Indicator Kit.

**Step 14: NOTE, AOD Only:** Verify that the internal T.V. lever is still aligned with the T.V. piston. Install the external T.V. lever, following the instructions that are provided in that kit. This will prevent the internal T.V. lever from becoming misaligned.

**All:** (Disregard this step if you did not have to remove the pan.) Reinstall the filter and the transmission pan. Fill with the appropriate amount of transmission fluid.

**Step 15:** The column shift arm could be one of several different designs, and the type of column shift arm you have will determine how the Delrin® bushings will be positioned. If the raised shoulder in the center of the provided Delrin® bushings will fit inside the hole in the column shift arm, then the Delrin® bushings will be installed with the raised shoulders facing each other inside the column shift arm. If the raised shoulder in the center of the provided Delrin® bushings will **NOT** fit inside the hole in the column shift arm, then the Delrin® bushings will be installed with the raised center shoulders facing outwards.

**NOTE:** Some aftermarket steering columns may require that you drill out the column shift arm to fit the bushings. The new hole diameter should be 0.625" (5/8").

Attach the 5/16"-24 female rod end to the column shift arm with the 5/16"-24 x 1-1/2" hex head bolt. Install a small flat washer onto the bolt first, and then slide on the female rod end. Next install the large diameter flat washer, and one Delrin® bushing facing the proper direction. Insert the bolt through the column shift arm, and then install the other Delrin® bushing and small flat washer. Secure it all using the 5/16"-24 nylock nut as shown in **Fig. 14**.

**NOTE:** These items can be installed in the reverse order if necessary for clearance or proper alignment.

**Step 16:** Thread the stainless steel rod into the rod end on the column shift arm and up to the jam nut, leaving about 1/4" of threads exposed beyond the jam nut.

**Step 17:** Check to make sure that nothing will interfere with connecting the stainless steel rod to the trans arm. If required, the stainless steel rod can be bent to clear other components, starting at the steering column end.

**Step 18:** Make sure both the shifter lever on the column and the transmission are in "Park". Line up the transmission end of the stainless steel rod with the center of the slot in the trans arm, and mark the stainless steel rod at the center of the trans arm slot. Cut the stainless steel rod 1-3/4" back towards the column end from your mark, using a hacksaw or cutoff wheel.

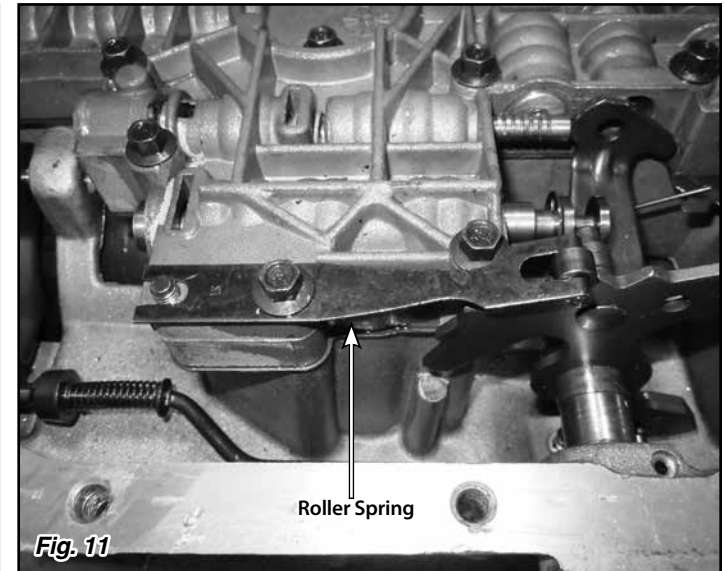
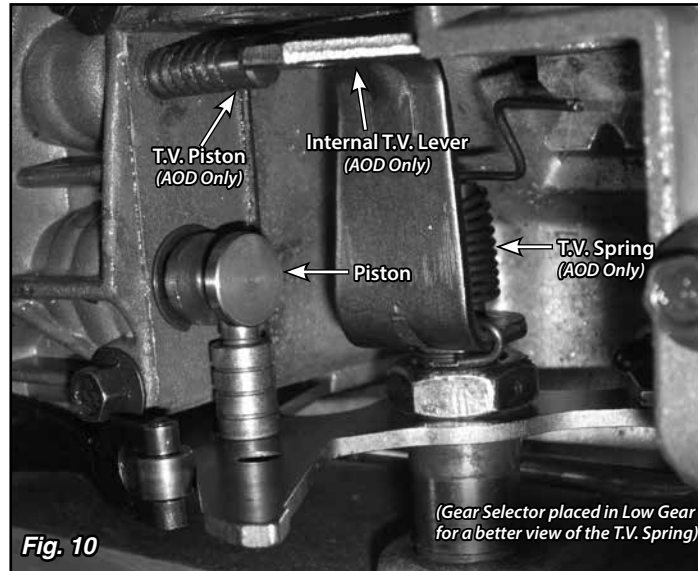
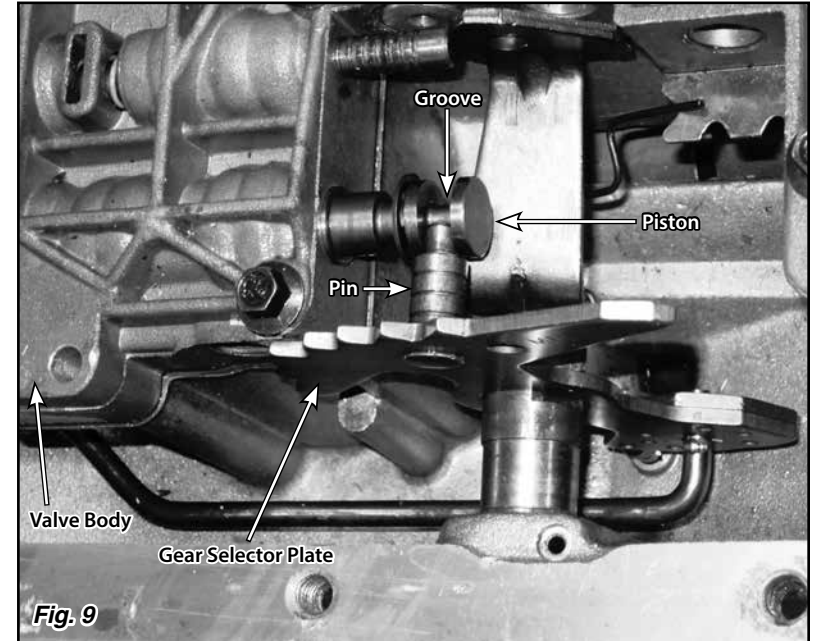
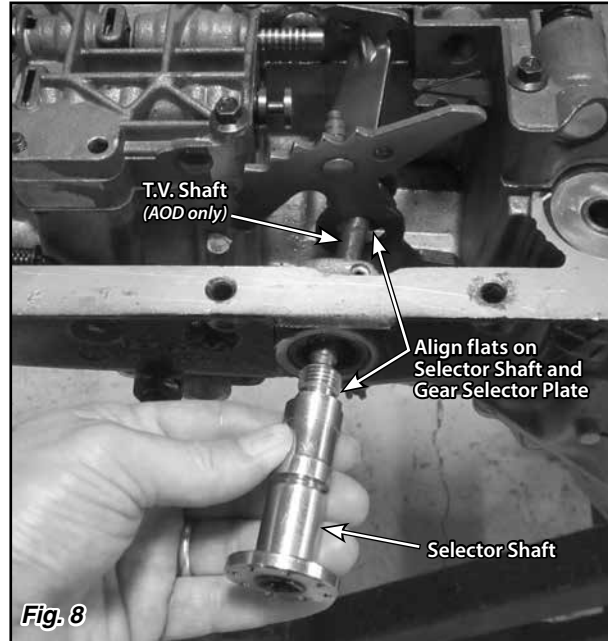

# Column Shift Linkage Installation Instructions for Ford AOD, 4R70W, and AODE

**Step 19:** Slide the hex connector with the second 5/16"-24 female rod end onto the end of the stainless steel rod. Attach the rod end to the trans arm with the 5/16"-24 x 1-1/4" hex head bolt, two flat washers, and nylock nut as shown in **Fig. 14**. Tighten the set screws in the hex connector using a 1/8" hex wrench, but only enough to mark the stainless steel rod and hold the hex connector in place during the adjustment procedure.

**Step 20:** Adjust the column shift linkage so that the shift lever will enable you to get the transmission into all gear ranges. Once you have the final adjustment done, tighten the jam nuts at both ends of the stainless steel rod.

**Step 21:** Disconnect the stainless steel rod from the hex connector and grind two small flat spots on the rod where each of the set screws contact it (this will help maintain the position of the rod). Apply thread locking compound (not supplied) to the set screws, and then install and tighten them.

See **Fig. 15** for a completed installation.

