

General Installation Notes:

Please read these instructions completely before beginning the installation. If you have any questions please call.

Before beginning the installation, disconnect the negative battery cable and use wheel chocks to block the vehicle's wheels.

Refer to Fig. 1 for the component names.

The Coil Relocation Kits are designed to work with LS2, LS3, LS7, and LS9 ignition coils. They will not work with truck or LS1 ignition coils.

- Step 1:** Remove any necessary existing parts before beginning the installation.
- Step 2:** Determine the new location for the ignition coils. Make sure you have enough free space to mount them. Each coil bracket will hold two coils, and the coil brackets must be spaced far enough apart to enable that.
- Step 3:** Fasteners to attach the coil brackets to your vehicle are not included. The coil brackets are designed to accept 1/4" diameter button head bolts. Determine what fasteners will work the best for your mounting location, and obtain those fasteners.
- Step 4:** Using a coil bracket as a pattern, mark the locations of the mounting holes onto your vehicle. Center punch the marks. Drill each hole, using a drill bit that is the correct size for your fasteners.
- Step 5:** Install the coil brackets onto the vehicle, using the fasteners that you chose.
- Step 6:** Position a coil on one side of a coil bracket. Install two of the provided 1/4"-20 x 2-1/2" button head bolts through the first coil and through the mount bracket. **Fig. 2**

NOTE, Delphi coils only: Install a spacer onto each bolt. Slide the second coil onto the bolts. Install and tighten a nylock nut onto each bolt. Repeat for the other three coil brackets.

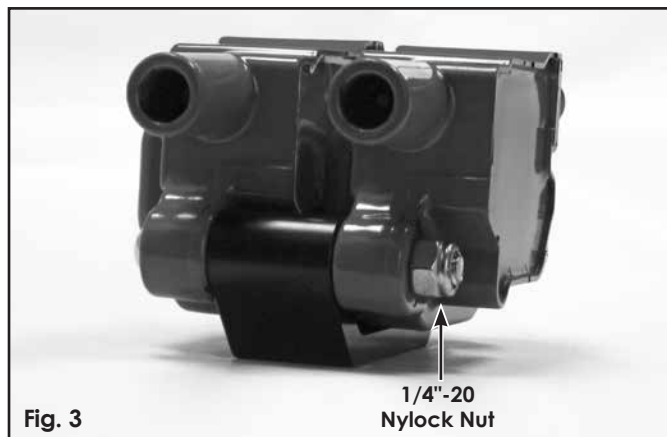
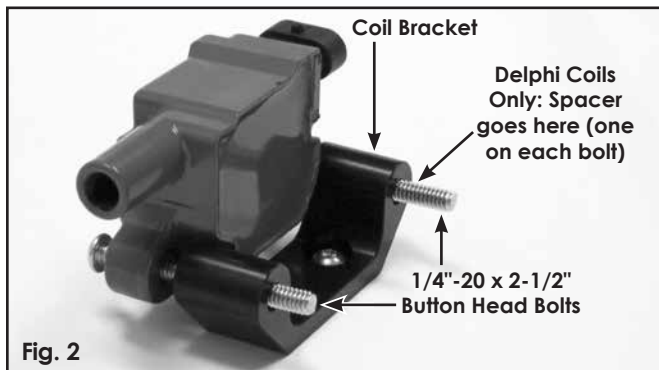
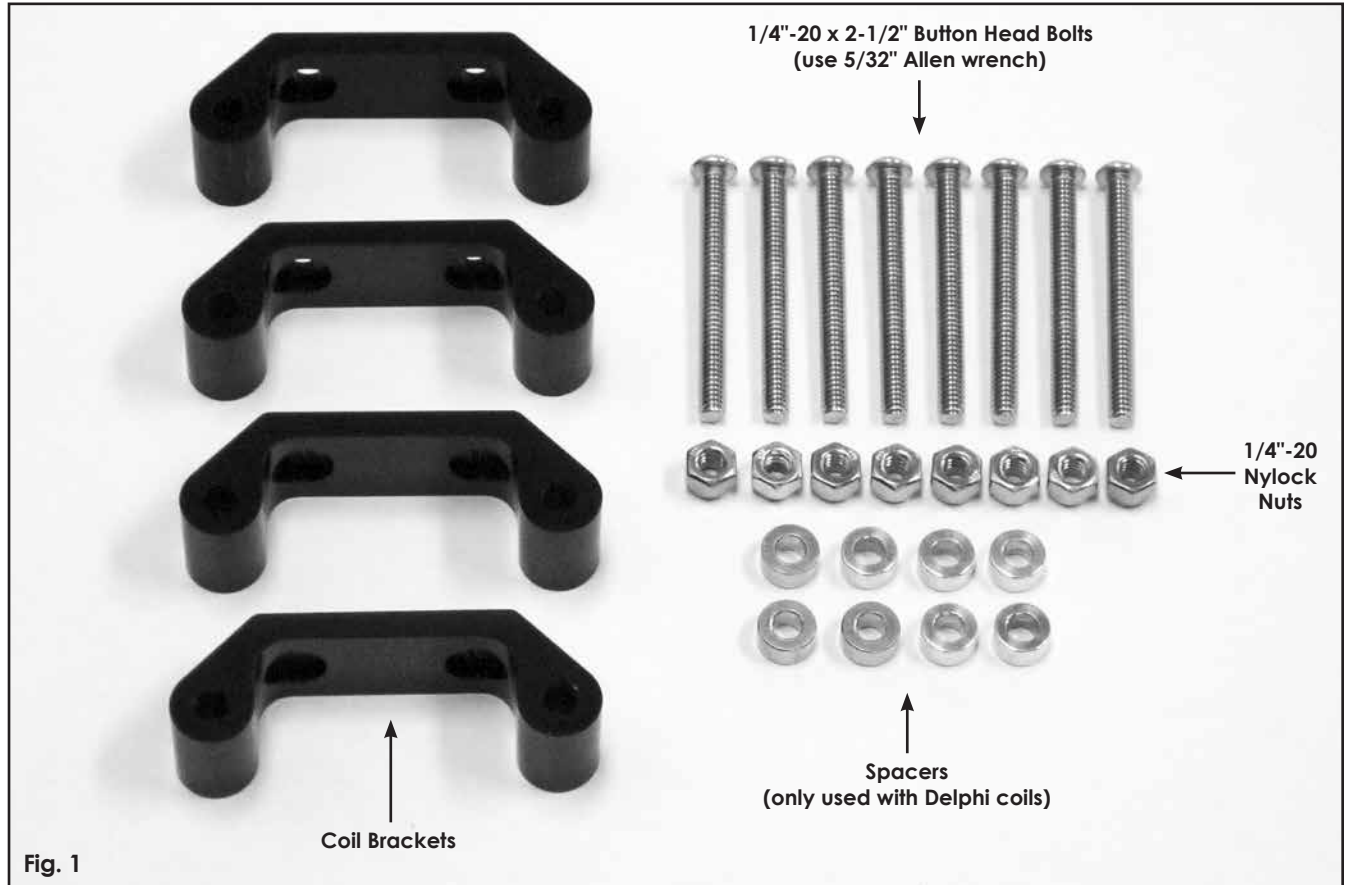

**CLAYTON
MACHINE
WORKS**

LS Coil
Relocation Kit
Installation
Instructions

CLAYTON MACHINE WORKS

865 - 824 - 9778