

GM Floor Mount Gated Automatic Transmission Shifter Installation Instructions



GM Floor Mount Gated Automatic Transmission Shifter Installation Instructions

Building American Quality... With A Lifetime Warranty!

TOLL FREE 1-877-469-7440 • tech@lokar.com • www.lokar.com

General Installation Notes:

Please read these instructions completely before beginning the installation. If you have any questions, please call.

Before beginning the installation, disconnect the negative battery cable and use wheel chocks to block the vehicle's wheels.

Make sure the engine, transmission, body and frame are properly grounded. We recommend using anti-seize lubricant on all aluminum threads.

Refer to Fig. 1 for the component names.

Tools and Materials Required:

- Standard Allen wrenches: 1/8", 5/32", 3/16"
- Wrench or Socket Sizes: 3/8", 7/16", 1/2", 9/16", 13mm (metric transmissions only)
- Tape Measure
- Metal cutting tool, such as a hacksaw or a die grinder with a cut-off wheel
- Drill and 5/16" drill bit
- Ohmmeter
- Wire cutters/strippers
- Wire crimping or soldering tools
- Blue thread locking compound

This Shifter is designed to fit specific transmission models. Before installation, verify that you have the proper Shifter for your transmission. If your Shifter does not seem to connect to the transmission properly, do not make modifications during installation as this may void your warranty. Call for assistance.

This Clayton Machine Works Shifter is designed to be installed to the rear of the transmission selector shaft. If you need the Shifter to be located close to or in front of the transmission selector shaft, you will need a bellcrank kit or cable conversion kit (available separately).

The Shifter must be installed into the vehicle before attempting to make any adjustments.

To move the Shifter out of Park, pull the Shifter Lever towards the driver side, and then pull the Shifter Lever rearward into Reverse. Pull the Shifter Lever rearward again to go into Neutral. Let go of the Shifter Lever, and it will spring back towards the passenger side. The Shifter Lever can then be pulled rearward again into Drive (or Overdrive). To access the lower gears, move the Shifter Lever towards the driver side again, and pull rearward.

Step 1: If your vehicle already has a shifter of any type installed, disconnect all shifter linkage and remove the shifter and its related hardware (neutral safety switch, back-up light switch, etc.).

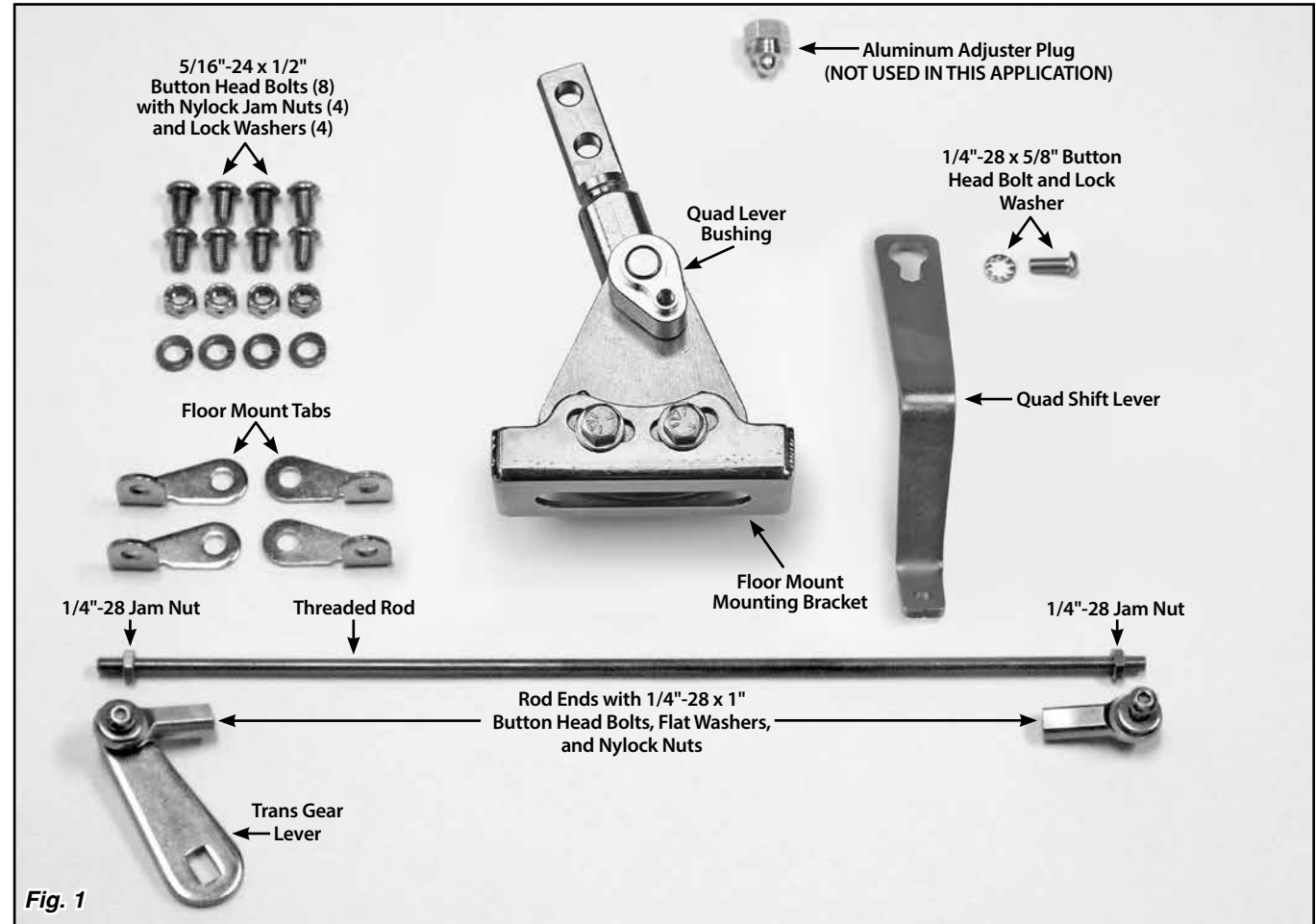

Fig. 1

Step 2: Determine exactly where you want the Shifter to be located. The Shifter may be mounted either on top of the floor or underneath the floor.

NOTE: For vehicles that had a floor shifter previously, determine if the existing hole(s) in the floor will be adequate for mounting and operation of the Shifter. If not, the floor will need to be modified.

If you are mounting the Shifter on top of the floor, you will need a slot in the floor for the quad shift lever to pass through. If you are mounting the Shifter underneath the floor, the opening will need to be large enough for the floor mount mounting bracket also.

Step 2, continued: The bottom end of the quad shift lever should be generally aligned with the trans gear lever on the transmission. It is not necessary that the quad shift lever be perfectly aligned with the trans gear lever. The rod ends allow for a certain amount of misalignment.

NOTE: Some shifter boots and boot rings will NOT work with a Clayton Machine Works Floor Mount Shifter if the Shifter Boot and Boot Ring are also mounted directly on the floor.

Step 3: There are two pairs of floor mount tabs in the Shifter Kit. Which pair goes where will depend on if you are mounting the Shifter above or below the floor. See **Fig. 2** to determine how the floor mount tabs need to be positioned for your particular application.

The floor mount tabs on the rear of the Shifter **must** be installed with the ears pointing towards the rear of the vehicle. You may install the front floor mount tabs facing either direction, but installing the front floor mount tabs pointing rearward is less likely to interfere with fitment of a shifter boot and boot ring.

Attach the floor mount tabs to the floor mount mounting bracket as shown in **Fig. 2** with the 5/16"-24 x 1/2" button head bolts and lock washers. Leave the bolts loose enough so that adjustments can be made later during the installation.

Step 4: Tremec Style Lever Only - If your Shifter did not come with the Shifter Lever already installed, install the Shifter Lever using your original 3/8"-24 bolts, or the 3/8"-24 bolts that came with the Shifter Lever (if applicable). **Fig. 3**

Step 5: Make sure the two 5/16"-24 x 2-1/4" hex head bolts and nylock nuts that are in the curved, slotted holes in the floor mount mounting bracket are tight. Place the Shifter in the desired location on the vehicle's floor. Make sure the shifter lever will not interfere with the dash when in Park, or with the seat when in low gear. The shifter assembly may be tilted forward or backward if needed by loosening the nylock nuts on the two 5/16"-24 x 2-1/4" hex head bolts that are in the curved, slotted holes in the floor mount mounting bracket. Retighten the nylock nuts once you have the shifter assembly at the angle you want. **Fig. 4**

Step 6: Determine the size and location of any opening(s) that need to be cut in the floor in order to mount the shifter assembly and allow full travel of the quad shift lever. It may be useful to temporarily mount the quad shift lever to the quad lever bushing and move the shifter lever through its full range of motion, in order to help determine where the cuts need to be made.

Cut those openings now.

Step 7: Place the shifter assembly in position on the vehicle. Push the floor mount tabs flush against the floor, and mark the center of the bolt holes in the floor mount tabs onto the floor. Center punch the marks, and drill four 5/16" diameter holes.

Step 8: Attach the floor mount tabs to the floor using four 5/16"-24 x 1/2" button head bolts and nylock jam nuts. Once the shifter assembly is mounted to the floor, tighten the floor mount tab to floor mount mounting bracket bolts.

Step 9: Temporarily place the quad shift lever in position on the quad lever bushing as shown in **Fig. 5**. Check for interference with the driver side rear floor mount tab or the vehicle floor. With the shifter lever in Park, you want the quad shift lever to be as close to the 4:30 - 5:00 position as the floor mount tab will allow, without the quad shift lever touching the floor mount tab or floor.

If the quad shift lever is not pointed towards the 4:30 - 5:00 position, loosen the set screw in the top of the quad lever bushing using a 1/8" Allen wrench. Slide the quad lever bushing off of the shifter. Reinstall the bushing pointed towards approximately the 4:30 - 5:00 position as shown. Re-tighten the set screw.

With the quad shift lever in position on the quad lever bushing, install the 1/4"-28 x 5/8" button head bolt and lock washer into the bushing, and tighten with a 5/32" Allen wrench.

Step 10: Make sure the transmission is in Park by rotating the original trans gear lever clockwise as far as it will go. Remove the original nut and trans gear lever from the transmission selector shaft. Install the new trans gear lever onto the selector shaft, pointed up and slightly towards the rear, at approximately the 1:00 position.

Secure the new trans gear lever with your original nut. **Fig. 6**

Step 11: The threaded rod will connect the quad shift lever to the trans gear lever. Check to make sure that nothing will interfere with the travel of the threaded rod. Some transmission cases have an external casting feature that may need to be trimmed slightly with a grinder to prevent interference with the threaded rod, depending on the location of your shifter.

If there is any interference, the threaded rod can be bent slightly as needed.

4L60E transmissions with a Manual Lever Position Sensor (MLPS) on the selector shaft will likely require an offset bend in the threaded rod in order to clear the sensor.

Verify that both the shifter lever and the transmission are in the Park position. Measure center-to-center between the 1/4" holes in the trans gear lever on the transmission and the quad shift lever on the Shifter. Subtract 1-3/4". **Fig. 7** This is the length you will cut the threaded rod to. Use a hacksaw or cutoff wheel to shorten the threaded rod. Then, de-burr the cut end of the rod.

Step 12: Make sure that two 1/4"-28 jam nuts are installed on the threaded rod, one at each end. Install a rod end onto each end of the threaded rod. Position the rod ends on the inside or outside of the quad shift lever and trans gear lever so that the threaded rod is as straight as possible. Attach the threaded rod assembly to the quad shift lever and trans gear lever using the 1/4"-28 x 1" button head bolts, flat washers, and nylock nuts as shown in **Fig. 8**. The button head bolts can be installed from either direction, but make sure the rod ends are sandwiched between the flat washers and the quad shift lever or trans gear lever. **Fig. 9**

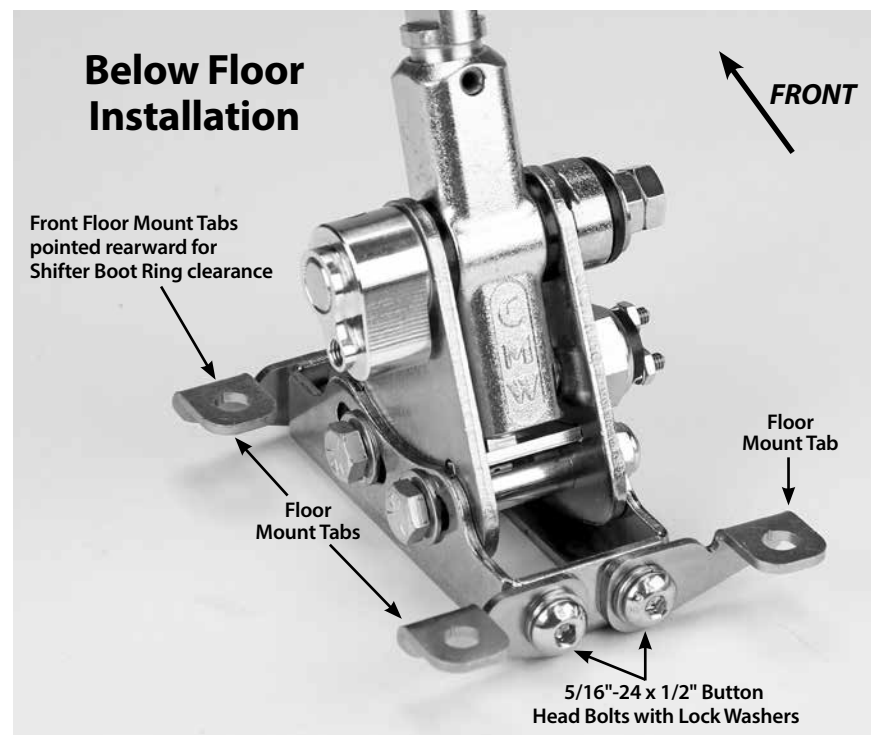
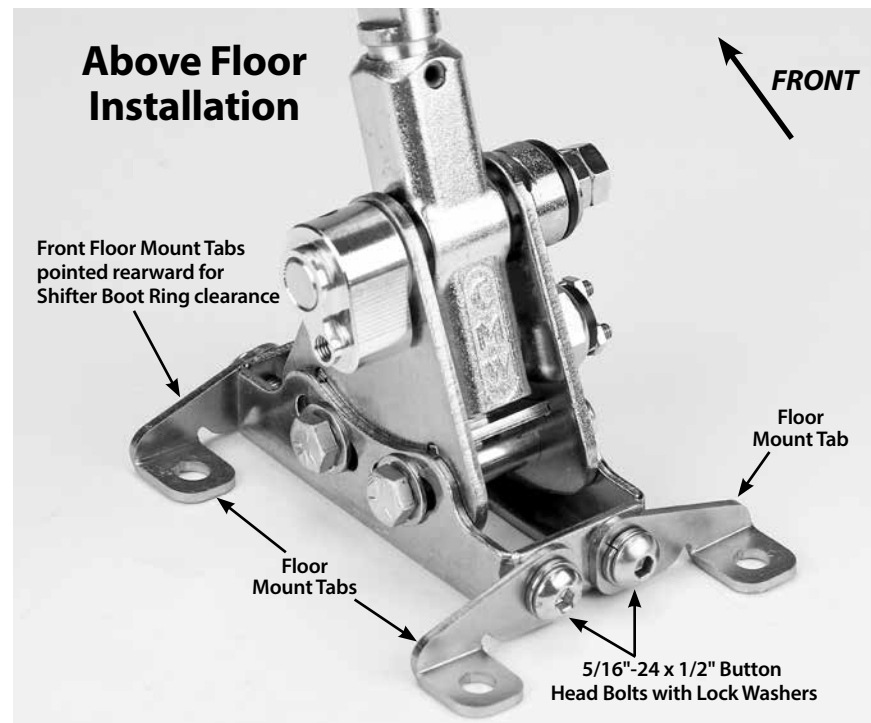

Fig. 2



Fig. 3

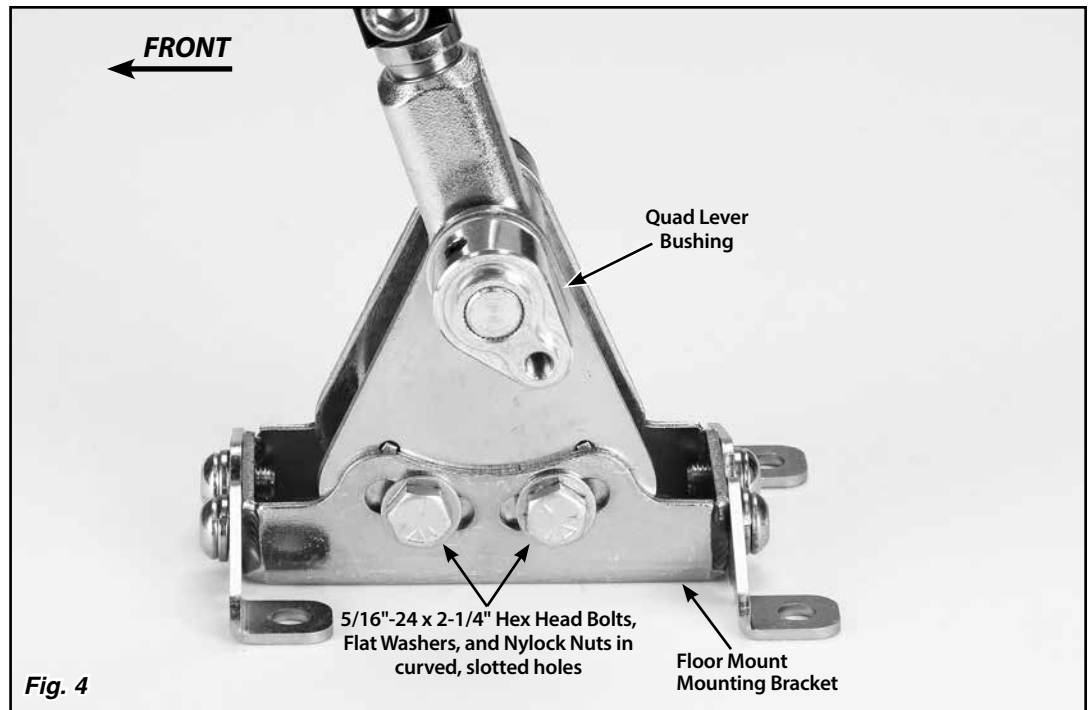

Fig. 4

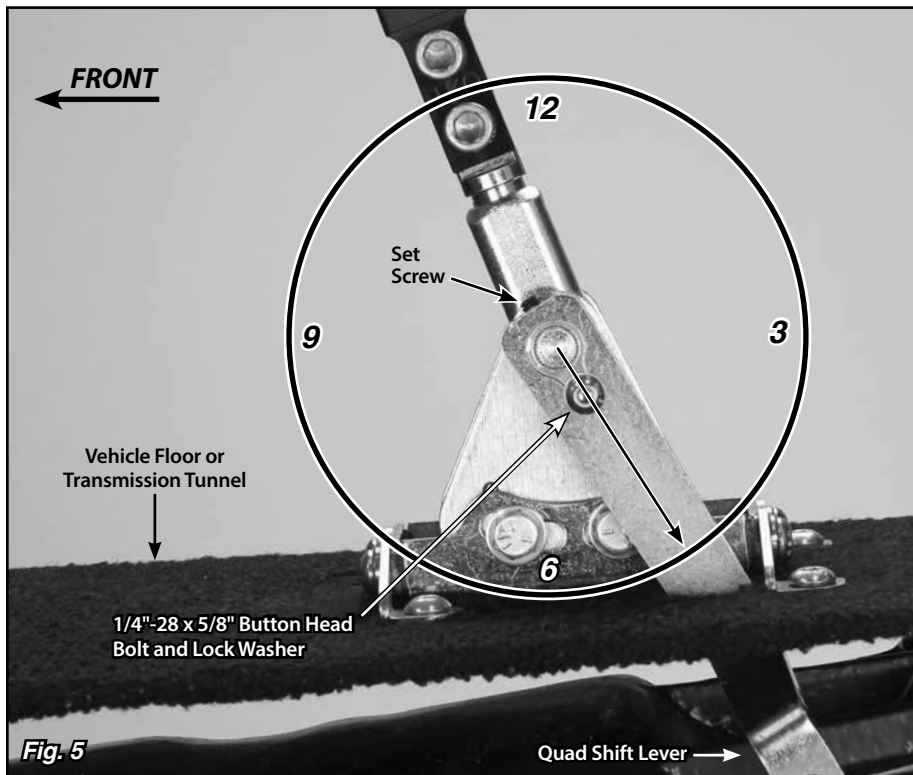

Fig. 5

Step 13: Check the adjustment of the shifter linkage by placing the shifter lever all the way forward into the Park position.

While the shifter lever is in the Park position, make sure the transmission is firmly in the "Park" detent, with no tension on the threaded rod. You can verify this by removing the 1/4"-28 x 1" button head bolt with nylock nut that attaches the rod end to the quad shift lever or trans gear lever at either end of the threaded rod. Make sure the hole in the rod end exactly aligns with the hole in the quad shift lever or trans gear lever. The bolt should pass freely through both holes at the same time without binding. Do not force the holes to line up.

If the holes are not aligned, screw the rod end in or out just enough to be able to slide the bolt in and out without putting tension on the threaded rod. Make sure that the quad shift lever and trans gear lever do not move during the adjustment procedure. Use this adjustment routine until the bolt will pass freely in and out of both the rod end and the quad shift lever or trans gear lever. Reinstall the 1/4"-28 nylock nut and the flat washer in its proper position onto the bolt, and tighten.

Once you have the shifter linkage adjusted correctly, tighten the jam nuts on the threaded rod.

Neutral Safety Switch Wiring

NOTE: The Neutral Safety Switch will have one or more washers under it. The washer(s) are used to adjust the depth of the neutral safety switch for proper operation. If the neutral safety switch is ever removed for any reason, you **MUST** reinstall the same washer(s) with the neutral safety switch to maintain the adjustment. **Fig. 10**

The shifter's Neutral Safety Switch is a simple on/off, non-directional switch. The switch passes current (turns on) when the ball is pushed in. It does not pass current (turns off) when the ball is out at its at-rest position.

Step 14: Connect the neutral safety switch between your ignition switch and starter circuits. Check the wiring of your fuse panel:

- **If there are (2) connections for a neutral safety switch**, run a #12 (or heavier) stranded wire from these terminals in your fuse panel to the (2) terminals on the neutral safety switch. That completes the Neutral Safety Switch wiring.
- **If your fuse panel does not have neutral safety switch connections**, locate the wire going from the ignition switch to the starter. If GM color codes are used, this wire will usually be purple. After locating the wire, disconnect it from the starter. It must be cut and routed from the ignition switch to one of the neutral safety switch terminals, and from the other neutral safety switch terminal to the same stud on the starter where the original wire was removed. If the wire must be lengthened, be sure to use wire that is at least the same size or larger than the original.

Step 15: Reconnect the negative battery cable and check operation. Make sure that the engine will not start in reverse or a drive gear. If it does, try adding a thin washer or shim (any material is OK, such as gasket material) under the neutral safety switch. If the engine will not start in Park or Neutral, remove one of the washers from underneath the neutral safety switch, and try it again. Tighten all brackets and bolts correctly and securely and there should be no movement or maladjustment. If you have any questions after following this procedure, please call Clayton Machine Works Technical Support.

